



MDD TEST REPORT

Report No.: SET2017-00303

Product: Pulse Oximeter

Model No. : C101H1, C101A2, C101A3, C101B1, C101B2

Brand Name: /

Applicant: Shenzhen IMDK Medical Technology Co., Ltd.

Issued by: CCIC Southern Electronic Product Testing (Shenzhen) Co., Ltd.

Lab Location: Electronic Testing Building, No. 43 Shahe Road, Xili Jiedao,
Nanshan District, 518055 Shenzhen, Guangdong, China

Tel: 86 755 26627338 **Fax:** 86 755 26627238



This test report consists of **110** pages in total. It may be duplicated completely for legal use with the approval of the applicant. It should not be reproduced except in full, without the written approval of our laboratory. The client should not use it to claim product endorsement by CCIC-SET. The test results in the report only apply to the tested sample. The test report shall be invalid without all the signatures of testing engineers, reviewer and approver. Any objections must be raised to CCIC-SET within 15 days since the date when the report is received. It will not be taken into consideration beyond this limit.





TEST REPORT IEC 60601-1 Medical electrical equipment Part 1: General requirements for basic safety and essential performance	
Compiled by (+ signature)	Macy. Yang <i>Macy Yang</i>
Reviewed by (+ signature).....	Bonnie. Nie <i>Bonnie. Nie</i>
Approved by (+ signature)	Smart. Li <i>Smartli</i>
Date of issue.....	2017.05.19
Testing Laboratory	CCIC Southern Electronic Product Testing (Shenzhen) Co., Ltd.
Address.....	Electronic Testing Building, No. 43 Shahe Road, Xili Jiedao, Nanshan District, 518055 Shenzhen, Guangdong, China Tel: 86-755-26627338 Fax: 86-755-26627238
Applicant's name	Shenzhen IMDK Medical Technology Co., Ltd.
Address.....	C Zone, 10F, Building 16, Yuanshan Industrial B Area, Gongming Street, Guangming District, Shenzhen
Test specification:	
Standard	IEC 60601-1: 2005 + CORR. 1:2006 + CORR. 2:2007 + AM1:2012 (or IEC 60601-1: 2012 reprint) ANSI/AAMI ES60601-1:2005/ (R)2012 and A1:2012, C1:2009/ (R)2012 and A2:2010/(R)2012
Test procedure	Test report only
Non-standard test method.....	Not applicable
Test Report Form No.	IEC60601_1J
Test Report Form(s) Originator	UL(US)
Master TRF	2014-07
Test item description	Pulse Oximeter
Trade Mark	/
Manufacturer	Shenzhen IMDK Medical Technology Co., Ltd.
Address.....	C Zone, 10F, Building 16, Yuanshan Industrial B Area, Gongming Street, Guangming District, Shenzhen
Model/Type reference.....	C101H1, C101A2, C101A3, C101B1, C101B2
Ratings.....	DC 3V (2X1.5V AAA battery)





Copy of marking plate

Pulse Oximeter

Model: C101H1

Input Voltage:DC 3.0V(2XAAA)  

SN C101H1160800008

EC REP Mednet GmbH   0123  

Add: Borkstrasse 10, 48163
Münster, Germany **IP22** 

.....

 Shenzhen IMDK Medical Technology CO., Ltd
Add : C Zone, 10F, Building 16, Yuanshan
Industrial B Area, Gongming Street,
Guangming District, Shenzhen.

Test item particulars	
Classification of installation and use	Hand-held
Mode of operation	Continuous
Supply Connection	Internally powered
Accessories and detachable parts included	Refer to user manual
Possible test case verdicts:	
- test case does not apply to the test object	N (Not applicable)
- test object does meet the requirement	P (Pass)
- test object does not meet the requirement	F (Fail)
Testing	
Date of receipt of test item	2016-08-30
Date (s) of performance of tests	2017-01-01 to 2017-05-12
- Normal condition	N.C.
- Single fault condition	S.F.C.
- Means of Operator protection	MOOP
- Means of Patient protection	MOPP
General remarks:	
<p>"(See Attachment #)" refers to additional information appended to the report. "(See appended table)" refers to a table appended to the report. The tests results presented in this report relate only to the object tested. This report shall not be reproduced except in full without the written approval of the testing laboratory. List of test equipment must be kept on file and available for review. Additional test data and/or information provided in the attachments to this report.</p>	
General product information:	
<p>1. This device intended for use in measuring and displaying functional oxygen saturation of arterial hemoglobin (%SpO2) and pulse rate (PR). The device can be powered by alkaline batteries (2X1.5V AAA battery)</p> <p>2. There are 5 models, they are the same except the colour of appearance, which does not affect the basic safety and essential performance. Based on the differences above, model C101H1 is picked up for the whole test</p>	

IEC 60601-1			
Clause	Requirement + Test	Result - Remark	Verdict

INSULATION DIAGRAM

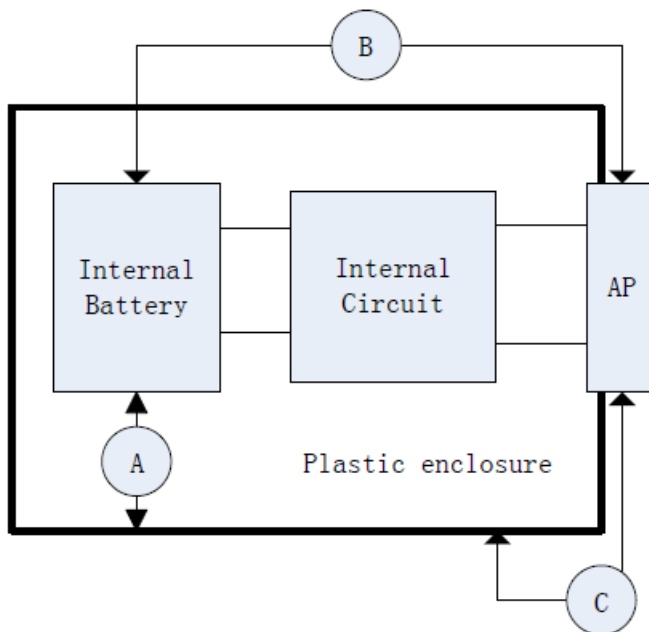

TABLE: To insulation diagram								P	
Pollution degree								II	—
Overvoltage category								II	—
Altitude								<3000m	—
Additional details on parts considered as applied parts								<input checked="" type="checkbox"/> None <input type="checkbox"/> Areas _____ (See Clause 4.6 for details)	—
Area	Number and type of Means of Protection: MOOP, MOPP	CTI (IIIb, unless is known)	Working voltage		Required creepage (mm)	Required clearance (mm)	Measured creepage (mm)	Measured clearance (mm)	Remarks
			Vrms	Vpk					
A	2 MOOP	IIIb	/	3V d.c.	1.0	0.9	--	--	Battery to enclosure ^{1, 2}
B	2 MOPP	IIIb	/	3V d.c.	3.4	1.6	>10	>10	Battery to AP
C	1 MOPP	IIIb	250	354	4.0	2.5	--	--	AP to enclosure ^{1, 3}

IEC 60601-1			
Clause	Requirement + Test	Result - Remark	Verdict

TABLE: To insulation diagram		P
Pollution degree	II	—
Overvoltage category	II	—
Altitude	<3000m	—
Additional details on parts considered as applied parts	<input checked="" type="checkbox"/> None <input type="checkbox"/> Areas _____ (See Clause 4.6 for details)	—

Area	Number and type of Means of Protection: MOOP, MOPP	CTI (IIIb, unless is known)	Working voltage		Required creepage (mm)	Required clearance (mm)	Measured creepage (mm)	Measured clearance (mm)	Remarks
			Vrms	Vpk					

Note:

- 1) After inspection of circuit arrangement and components, the equipment, which is powered by DC 3V battery, is deemed to provide electrical protection to the internal circuit by impedances, therefore through the leakage current test to check is enough.
- 2) The metal battery holder is fixed on plastic battery box, the touch current is 0uA.
- 3) The AP is fixed on plastic enclosure, patient leakage current with mains on the AP is 1uA.

INSULATION DIAGRAM CONVENTIONS and GUIDANCE:

Insulation diagram is a graphical representation of equipment insulation barriers, protective impedance and protective earthing. If feasible, use the following conventions to generate the diagram:

- All isolation barriers are identified by letters between separate parts of diagram, for example separate transformer windings, optocouplers, wire insulation, creepage and clearance distances.
- Parts connected to earth with large dots are protectively earthed. Other connections to earth are functional
- Applied parts are extended beyond the equipment enclosure and terminated with an arrow.
- Parts accessible to the operator only are extended outside of the enclosure, but are not terminated with an arrow.

IEC 60601-1			
Clause	Requirement + Test	Result - Remark	Verdict
4	GENERAL REQUIREMENTS		P
4.1	Requirements of this standard applied in NORMAL USE and reasonably foreseeable misuse		P
4.2	RISK MANAGEMENT PROCESS FOR ME EQUIPMENT OR ME SYSTEMS		P
4.2.2	General requirement for RISK MANAGEMENT - PROCESS complies with ISO14971 (2007) :	See Appended RM Results Table 4.2.2.	P
4.2.3	Evaluating RISK		P
4.2.3.1	a) Compliance with the standard reduces residual risk to an acceptable level		P
	b) Manufacturer has defined risk acceptability criteria in the RISK MANAGEMENT PLAN	RISK MANAGEMENT PLAN Document: YMDK-RD-C101H1-0001/A0	P
	c) When no specific technical requirements provided manufacturer has determined HAZARDS or HAZARDOUS SITUATIONS exists.		P
	- HAZARDS or HAZARDOUS SITUATIONS have been evaluated using the RISK MANAGEMENT PROCESS.		P
4.2.3.2	MANUFACTURER has addressed HAZARDS or HAZARDOUS SITUATIONS not specifically addressed in the IEC 60601-1 series.		P
4.3	Performance of clinical functions necessary to achieve INTENDED USE or that could affect the safety of the ME EQUIPMENT or ME SYSTEM were identified during RISK ANALYSIS.	RM File Reference to Essential performance: YMDK-RD-C101H1-0003/A0, chapter 1	P
	- Performance limits were identified in both NORMAL CONDITION and SINGLE FAULT CONDITION.		P
	- Loss or degradation of performance beyond the limits specified by the MANUFACTURER were evaluated		P
	- Functions with unacceptable risks are identified as ESSENTIAL PERFORMANCE.....:	See Appended Table 4.3	P
	- RISK CONTROL measures implemented		P
	- Methods used to verify the effectiveness of RISK CONTROL measures implemented		P
4.4	EXPECTED SERVICE LIFE stated in RISK MANAGEMENT FILE	RM File Reference to: YMDK-RD-C101H1-0003/A0, chapter 1	P
4.5	Alternative RISK CONTROL methods utilized:		N
	RESIDUAL RISK resulting from the alternative RISK CONTROL measures or tests is acceptable and comparable to RESIDUAL RISK resulting from application of this standard		N
	(ISO 14971 Cl. 4.2-4.4, 5, 6.2-6.5)		
	Alternative means based scientific data or clinical opinion or comparative studies.....:		N

IEC 60601-1			
Clause	Requirement + Test	Result - Remark	Verdict
4.6	RISK MANAGEMENT PROCESS identifies parts that can come into contact with PATIENT but not defined as APPLIED PARTS, subjected to the requirements for APPLIED PARTS, except for Clause 7.2.10.....:	No such parts	N
	MANUFACTURER assesses the risk of accessible parts coming into contact with the patient.....: (ISO 14971 Cl. 4.2-4.4, 5, 6.2-6.5)		N
	Assessment identified the APPLIED PART TYPE requirements		N
4.7	ME EQUIPMENT remained SINGLE FAULT SAFE, or the RISK remained acceptable as determined by Clause 4.2.....:	RMF Reference to specific RISKS: YMDK-RD-C101H1-0005/A0	P
	MANUFACTURER RISK ANALYSIS was used to determine failures to be tested	RISK ANALYSIS REFERENCE: YMDK-RD-C101H1-0005/A0 and YMDK-RD-C101H1-0002/A0 (ISO 14971 Cl. 4.2-4.4)	P
	Failure of any one component at a time that could result in a HAZARDOUS SITUATION, including those in 13.1, simulated physically or theoretically	See appended Table 13.2 for simulated physical test	P
4.8	All components and wiring whose failure could result in a HAZARDOUS SITUATION used according to their applicable ratings, unless specified.....:	All components and wiring are used according to their applicable ratings	P
	Components and wiring exception in the standard or by RISK MANAGEMENT PROCESS		N
	RISK MANAGEMENT PROCESS assesses components to identify components where the failure results in a HAZARDOUS SITUATION for components used outside their ratings.....: (ISO 14971 Cl. 4.2-4.4, 5, 6.2-6.5)		N
	MANUFACTURER identified components where the failure results in a HAZARDOUS SITUATION	No such components, see appended table 13.2	N
	Components determined to be acceptable where used as a MEANS OF PROTECTION.....:	See appended Table 8.10	P
	Reliability of components used as MEANS OF PROTECTION assessed for conditions of use in ME EQUIPMENT, and they complied with one of the following		P
	a) Applicable safety requirements of a relevant IEC or ISO standard	See appended Table 8.10	P
	b) Requirements of this standard applied in the absence of a relevant IEC or ISO standard		P
4.9	A COMPONENT WITH HIGH-INTEGRITY CHARACTERISTICS provided and selected appropriately.....:	No high-integrity component	N

IEC 60601-1			
Clause	Requirement + Test	Result - Remark	Verdict
	RISK MANAGEMENT FILE includes an assessment to determine if the failure of components results in unacceptable RISK..... : (ISO 14971 Cl. 4.2-4.4, 5, 6.2-6.5)		N
	Components identified and required to be COMPONENTS WITH HIGH INTEGRITY CHARACTERISTIC:		N
4.10	Power supply		P
4.10.1	ME EQUIPMENT is suitable for connection to indicated power source (select applicable) :	Powered by INTERNAL ELECTRICAL POWER SOURCE	P
4.10.2	Maximum rated voltage for ME EQUIPMENT intended to be connected to SUPPLY MAINS:		N
	- 250 V for HAND-HELD ME EQUIPMENT (V)..... :		N
	- 250 V d.c. or single-phase a.c., or 500 V poly-phase a.c. for ME EQUIPMENT and ME SYSTEMS with a RATED input \leq 4 kVA (V) :		N
	- 500 V for all other ME EQUIPMENT and ME SYSTEMS		N
4.11	Power input		N
	Steady-state measured input of ME EQUIPMENT or ME SYSTEM at RATED voltage or voltage range and at operating settings indicated in instructions for use didn't exceed marked rating by more than 10% ... :	Powered by INTERNAL ELECTRICAL POWER SOURCE	N

5	GENERAL REQUIREMENTS FOR TESTING ME EQUIPMENT		P
5.1	Test not performed when analysis indicated condition being tested was adequately evaluated by other tests or methods :	All applicable tests are performed	N
	RISK MANAGEMENT FILE identifies combinations of simultaneous independent faults that could result in a HAZARDOUS SITUATION. (ISO 14971 Cl. 4.2-4.4)	No simultaneous independent fault	N
5.3	Tests conducted within the environmental conditions specified in technical description		P
	Temperature (°C), Relative Humidity (%) :	Temperature: 5-40 °C Relative Humidity: 15-80%	—
	Atmospheric Pressure (kPa)..... :	70-106	—
5.5	a) Supply voltage during tests was the least favourable of the voltages specified in 4.10.2 or voltages marked on ME EQUIPMENT (V) :	Powered by INTERNAL ELECTRICAL POWER SOURCE, not affect the test result	N
	b) ME EQUIPMENT marked with a RATED frequency range tested at the least favourable frequency within the range (Hz) :		N

IEC 60601-1			
Clause	Requirement + Test	Result - Remark	Verdict
	c) ME EQUIPMENT with more than one RATED voltage, both a.c./ d.c. or both external power and INTERNAL ELECTRICAL POWER SOURCE tested in conditions (see 5.4) related to the least favourable voltage, nature of supply, and type of current		N
	d) ME EQUIPMENT intended for only d.c. supply connection tested with d.c. and influence of polarity considered	Not d.c. supply connection	N
	e) ME EQUIPMENT tested with alternative ACCESSORIES and components specified in ACCOMPANYING DOCUMENTS to result in the least favourable conditions	No alternative ACCESSORIES and components	N
	f) ME EQUIPMENT connected to a separate power supply as specified in instructions for use	Not connected to a separate power supply	N
5.7	ME EQUIPMENT or parts thereof affected by climatic conditions were set up completely, or partially, with covers detached and subjected to a humidity preconditioning prior to tests of Clauses 8.7.4 and 8.8.3	Tests are performed according to requirement of standard	P
	ME EQUIPMENT heated to a temperature between T and T + 4°C for at least 4 h and placed in a humidity chamber and ambient within 2 °C of T in range of +20°C to +32°C for indicated time	T = 25°C Time = 168H	—
5.9	Determination of APPLIED PARTS and ACCESSIBLE PARTS		P
5.9.1	APPLIED PARTS identified by inspection and reference to ACCOMPANYING DOCUMENTS	Refer to chapter 4.1 "Classification" in user manual	P
5.9.2	ACCESSIBLE PARTS		P
5.9.2.1	Accessibility determined using standard test finger of Fig. 6	See Appended Table 5.9.2	P
5.9.2.2	Test hook of Fig. 7 inserted in all openings of ME EQUIPMENT and pulled with a force of 20 N for 10 s	No openings	N
5.9.2.3	Conductive parts of actuating mechanisms of electrical controls accessible after removal of handles, knobs, levers and the like regarded as ACCESSIBLE PARTS	No such parts	N
	Conductive parts of actuating mechanisms not considered ACCESSIBLE PARTS when removal of handles, knobs, required use of a TOOL		N
6	CLASSIFICATION OF ME EQUIPMENT AND ME SYSTEMS		P
6.2	CLASS I ME EQUIPMENT, externally powered		N
	CLASS II ME EQUIPMENT, externally powered		N
	INTERNALLY POWERED ME EQUIPMENT		P

IEC 60601-1			
Clause	Requirement + Test	Result - Remark	Verdict
	EQUIPMENT with means of connection to a SUPPLY MAINS complied with CLASS I or CLASS II ME EQUIPMENT requirements when so connected, and when not connected to SUPPLY MAINS with INTERNALLY POWERED ME EQUIPMENT requirements		N
	TYPE B APPLIED PART		N
	TYPE BF APPLIED PART		P
	TYPE CF APPLIED PART		N
	DEFIBRILLATION-PROOF APPLIED PARTS	No DEFIBRILLATION-PROOF APPLIED PARTS	N
6.3	ENCLOSURES classified according to degree of protection against ingress of water and particulate matter as per IEC 60529..... :	IP22	P
6.4	ME EQUIPMENT or its parts intended to be sterilized classified according to method(s) of sterilization in instructions for use	No need to sterilization	N
6.5	ME EQUIPMENT and ME SYSTEMS intended for use in an OXYGEN RICH ENVIRONMENT classified for such use and complied with 11.2.2	Not intended for use in an OXYGEN RICH ENVIRONMENT	N
6.6	CONTINUOUS or Non-CONTINUOUS OPERATION	Continuous operation	P

7	ME EQUIPMENT Identification, marking, and documents		P
7.1.2	Legibility of Markings Test for Markings specified in Clause 7.2-7.6..... :	See Appended Table 7.1.2	P
7.1.3	Required markings can be removed only with a TOOL or by appreciable force, are durable and remain CLEARLY LEGIBLE during EXPECTED SERVICE LIFE of ME EQUIPMENT in NORMAL USE	See appended Tables 7.1.3 and 8.10	P
7.2	Marking on the outside of ME EQUIPMENT or ME EQUIPMENT parts		P
7.2.1	At least markings in 7.2.2, 7.2.5, 7.2.6, 7.2.10, and 7.2.13 were applied when size of EQUIPMENT, its part, an ACCESSORY, or ENCLOSURE did not permit application of all required markings	See attached copy of Marking Plate	P
	Remaining markings fully recorded in ACCOMPANYING DOCUMENTS..... :	Refer to chapter 2.3 "Symbols" in user manual	P
	Markings applied to individual packaging when impractical to apply to ME EQUIPMENT		N
	Single use item marked	No single use parts	N
7.2.2	ME EQUIPMENT marked with:	See attached copy of Marking Plate	P
	– the name or trademark and contact information of the MANUFACTURER		P
	– a MODEL OR TYPE REFERENCE		P
	– a serial number or lot or batch identifier; and		P

IEC 60601-1			
Clause	Requirement + Test	Result - Remark	Verdict
	– the date of manufacture or use by date		N
	Detachable components of the ME EQUIPMENT not marked; misidentification does not present an unacceptable risk, or	No detachable component	N
	RISK MANAGEMENT FILE includes an assessment of the RISKS relating to misidentification of all detachable parts : (ISO 14971 Cl. 4.2-4.4, 5, 6.4)		N
	Detachable components of the ME EQUIPMENT are marked with the name or trademark of the MANUFACTURER, and		N
	– a MODEL OR TYPE REFERENCE		N
	Software forming part of a PEMS identified with a unique identifier :	Marked in software	P
7.2.3	Symbol 11 on Table D.1 used, optionally, advice to OPERATOR to consult ACCOMPANYING DOCUMENTS		N
	Safety sign 10 on Table D.2) used, advising OPERATOR that ACCOMPANYING DOCUMENTS must be consulted	See attached copy of Marking Plate	P
7.2.4	ACCESSORIES marked with name or trademark and contact information of their MANUFACTURER, and :	No accessory	N
	- with a MODEL or TYPE REFERENCE		N
	– a serial number or lot or batch identifier		N
	– the date of manufacture or use by date		N
	Markings applied to individual packaging when not practical to apply to ACCESSORIES		N
7.2.5	ME EQUIPMENT and ME SYSTEM intended to receive power from other equipment, provided with one of the following	No intended to receive power from other equipment	N
	- the name or trademark of the manufacturer of the other electrical equipment and type reference marked adjacent to the relevant connection point; or		N
	– Table D.2, safety sign No. 10 adjacent to the relevant connection point and listing of the required details in the instructions for use; or		N
	– Special connector style used that is not commonly available on the market and listing of the required details in the instructions for use.		N
7.2.6	Connection to the Supply Mains		N
	Marking appearing on the outside of part containing SUPPLY MAINS connection and, adjacent to connection point	Powered by INTERNAL ELECTRICAL POWER SOURCE	N
	For PERMANENTLY INSTALLED ME EQUIPMENT, NOMINAL supply voltage or range marked inside or outside of ME EQUIPMENT		N

IEC 60601-1			
Clause	Requirement + Test	Result - Remark	Verdict
	– RATED supply voltage(s) or RATED voltage range(s) with a hyphen (-) between minimum and maximum voltages (V, V-V)		N
	Multiple RATED supply voltages or multiple RATED supply voltage ranges are separated by (V/V).....		N
	– Nature of supply and type of current		N
	Symbols 1-5, Table D.1 (used for same parameters		N
	– RATED supply frequency or RATED frequency range in hertz.....		N
	– Symbol 9 of Table D.1 used for CLASS II ME EQUIPMENT		N
7.2.7	RATED input in amps or volt-amps, (A, VA)	Powered by INTERNAL ELECTRICAL POWER SOURCE	N
	RATED input in amps or volt-amps, or in watts when power factor exceeds 0.9 (A, VA, W)		N
	RATED input for one or more RATED voltage ranges provided for upper and lower limits of the range or ranges when the range(s) is/are greater than $\pm 10\%$ of the mean value of specified range (A, VA, W)		N
	Input at mean value of range marked when range limits do not differ by more than 10 % from mean value (A, VA, W).....		N
	Marking includes long-time and most relevant momentary volt-ampere ratings when provided, each plainly identified and indicated in ACCOMPANYING DOCUMENTS (VA)		N
	Marked input of ME EQUIPMENT provided with means for connection of supply conductors of other electrical equipment includes RATED and marked output of such means (A, VA, W)		N
7.2.8	Output connectors		N
7.2.8.2	Output connectors are marked, except for MULTIPLE SOCKET-OUTLETS or connectors intended for specified ACCESSORIES or equipment	No output connector	N
	Rated Voltage (V), Rated Current (A).....		—
	Rated Power (W), Output Frequency (Hz)		—
7.2.9	ME EQUIPMENT or its parts marked with the IP environmental Code per IEC 60529 according to classification in 6.3 (Table D.3, Code 2), marking optional for ME EQUIPMENT or parts rated IPX0.....	See attached copy of Marking Plate	P
7.2.10	Degrees of protection against electric shock as classified in 6.2 for all APPLIED PARTS marked with relevant symbols	See attached copy of Marking Plate	P
	TYPE B APPLIED PARTS with symbol 19 of Table D.1		N
	TYPE BF APPLIED PARTS with symbol 20 of Table D.1:		P

IEC 60601-1			
Clause	Requirement + Test	Result - Remark	Verdict
	TYPE OF APPLIED PARTS with symbol 21 of Table D.1:		N
	DEFIBRILLATION-PROOF APPLIED PARTS marked with symbols 25-27 of Table D.1.....:		N
	Proper symbol marked adjacent to or on connector for APPLIED PART	Marked adjacent to APPLIED PART	P
	Safety sign 2 of Table D.2 placed near relevant outlet.....:	No such outlet	N
	An explanation indicating protection of ME EQUIPMENT against effects of discharge of a cardiac defibrillator depends on use of proper cables included in instructions for use		N
7.2.11	ME EQUIPMENT suitable for CONTINUOUS OPERATION		P
	DUTY CYCLE for ME EQUIPMENT intended for non-CONTINUOUS OPERATION appropriately marked to provide maximum "on" and "off" time		N
7.2.12	Type and full rating of a fuse marked adjacent to ACCESSIBLE fuse-holder	No accessible fuse-holder	N
	Fuse type.....:		—
	Voltage (V) and Current (A) rating.....:		—
	Operating speed (s) and Breaking capacity		—
7.2.13	Physiological effects – safety sign and warning statements	No such physiological effects	N
	Nature of HAZARD and precautions for avoiding or minimizing the associated RISK described in instructions for use.....: (ISO 14971 Cl. 4.2-4.4, 5, 6.3)		N
7.2.14	HIGH VOLTAGE TERMINAL DEVICES on the outside of ME EQUIPMENT accessible without the use of a TOOL marked with symbol 24 of Table D.1	No high voltage terminal devices	N
7.2.15	Requirements for cooling provisions marked.....:	No such cooling provisions	N
7.2.17	Packaging marked with special handling instructions for transport and/or storage	No special handling instructions for transport or storage	N
	Permissible environmental conditions marked on outside of packaging		N
	Packaging marked with a suitable safety sign indicating premature unpacking of ME EQUIPMENT could result in an unacceptable RISK.....:	No such risks	N
	RISK MANAGEMENT FILE includes the assessment to determine premature unpacking of ME EQUIPMENT or its parts could result in an unacceptable RISK. . .: (ISO 14971 Cl. 4.2-4.4, 5, 6.3-6.4)		N
	Packaging of sterile ME EQUIPMENT or ACCESSORIES marked sterile and indicates the methods of sterilization	No sterilization	N

IEC 60601-1			
Clause	Requirement + Test	Result - Remark	Verdict
7.2.18	RATED maximum supply pressure from an external source marked on ME EQUIPMENT adjacent to each input connector, and	No supply pressure from an external source	N
	- the RATED flow rate also marked		N
7.2.19	Symbol 7 of Table D.1 marked on FUNCTIONAL EARTH TERMINAL	No FUNCTIONAL EARTH TERMINAL	N
7.2.20	Removable protective means marked to indicate the necessity for replacement when the function is no longer needed	No removable protective means	N
7.2.21	MOBILE ME EQUIPMENT marked with its mass including its SAFE WORKING LOAD in kilograms.....	Hand-held equipment	N
7.3	Marking on the inside of ME EQUIPMENT or ME EQUIPMENT parts		P
7.3.1	Maximum power loading of heating elements or lamp-holders designed for use with heating lamps marked near or in the heater (W)	No heating elements and lamp-holders	N
	A marking referring to ACCOMPANYING DOCUMENTS provided for heating elements or lamp-holders designed for heating lamps that can be changed only by SERVICE PERSONNEL using a TOOL		N
7.3.2	Symbol 24 of Table D.1, or safety sign No.3 of Table D.2 used to mark presence of HIGH VOLTAGE parts.....	No high voltage parts	N
7.3.3	Type of battery and mode of insertion marked.....	Marked in battery box	P
	An identifying marking provided referring to instructions in ACCOMPANYING DOCUMENTS for batteries intended to be changed only by SERVICE PERSONNEL using a TOOL.....	Primary battery, not intended to be recharged	N
	A warning provided indicating replacement of lithium batteries or fuel cells when incorrect replacement would result in an unacceptable RISK	No such risk	N
	RISK MANAGEMENT FILE includes an assessment to determine the replacement of lithium batteries or fuel cells leads to an unacceptable RISK if replaced incorrectly		N
	(ISO 14971 Cl. 4.2-4.4, 5, 6.3)		
	ACCOMPANYING DOCUMENTS contain a warning indicating the replacement of lithium batteries or fuel cells by inadequately trained personnel could result in a HAZARD		N
7.3.4	Fuses, replaceable THERMAL CUT-OUTS and OVER-CURRENT RELEASES, accessible by use of a TOOL Identified		N
	Voltage (V) and Current (A) rating.....		—
	Operating speed(s), size & breaking capacity.....		—
7.3.5	PROTECTIVE EARTH TERMINAL marked with symbol 6 of Table D.1	No PROTECTIVE EARTH TERMINAL	N

IEC 60601-1			
Clause	Requirement + Test	Result - Remark	Verdict
	Markings on or adjacent to PROTECTIVE EARTH TERMINALS not applied to parts requiring removal to make the connection, and remained visible after connection made		N
7.3.6	Symbol 7 of Table D.1 marked on FUNCTIONAL EARTH TERMINALS	No functional earth terminals	N
7.3.7	Terminals for supply conductors marked adjacent to terminals	No such supply conductors	N
	Terminals for supply connections are not marked, the RISK MANAGEMENT FILE includes an assessment of the RISKS resulting from misconnections: (ISO 14971 Cl. 4.3)		N
	Terminal markings included in ACCOMPANYING DOCUMENTS when ME EQUIPMENT too small to accommodate markings		N
	Terminals exclusively for neutral supply conductor in PERMANENTLY INSTALLED ME EQUIPMENT marked with Code 1 of Table D.3		N
	Marking for connection to a 3-phase supply, complies with IEC 60445		N
	Markings on or adjacent to electrical connection points not applied to parts requiring removal to make connection, and remained visible after connection made		N
7.3.8	"For supply connections, use wiring materials suitable for at least X °C" or equivalent, marked at the point of supply connections	No permanently installed me equipment	N
	Statement not applied to parts requiring removal to make the connection, and CLEARLY LEGIBLE after connections made		N
7.4	Marking of controls and instruments		P
7.4.1	The "on" & "off" positions of switch to control power to ME EQUIPMENT or its parts, including mains switch, marked with symbols 12 and 13 of Table D.1 or		N
	– indicated by an adjacent indicator light, or		N
	– indicated by other unambiguous means		N
	The "on/off" positions of push button switch with bi-stable positions marked with symbol 14 of Table D.1, and		N
	– status indicated by adjacent indicator light		N
	– status indicated by other unambiguous means		N
	The "on/off" positions of push button switch with momentary on position marked with symbol 15 of Table D.1 or		N
	– status indicated by adjacent indicator light		N
	– status indicated by other unambiguous means		N

IEC 60601-1			
Clause	Requirement + Test	Result - Remark	Verdict
7.4.2	Different positions of control devices/switches indicated by figures, letters, or other visual means		P
	RISK MANAGEMENT FILE identifies controls where a change in setting during NORMAL USE results in an unacceptable RISK..... : (ISO 14971 Cl. 4.2-4.4, 5, 6.2, 6.3)	No such RISK	N
	Controls provided with an associated indicating device when change of setting of a control could result in an unacceptable RISK to PATIENT in NORMAL USE..... :		N
	– or an indication of direction in which magnitude of the function changes		N
	Control device or switch that brings the ME EQUIPMENT into the "stand-by" condition marked with symbol IEC 60417-5009		P
7.4.3	Numeric indications of parameters on ME EQUIPMENT expressed in SI units according to ISO 80000-1 except the base quantities listed in Table 1 expressed in the indicated units		P
	ISO 80000-1 applied for application of SI units, their multiples, and certain other units		P
	All Markings in Sub-clause 7.4 complied with tests and criteria of 7.1.2 and 7.1.3..... :	See Appended Table 7.1.2 and 7.1.3	P
7.5	Safety signs		P
	Safety sign with established meaning used		P
	RISK MANAGEMENT PROCESS identifies markings used to convey a warning, prohibition or mandatory action that mitigate a RISK not obvious to the OPERATOR..... : (ISO 14971 Cl. 4.2-4.4, 5, 6.3)	RMF Reference to specific RISKS: YMDK-RD-C101H1-0005/A0, YMDK-RD-C101H1-0002/A0, and YMDK-RD-C101H1-0007/A01 (ISO 14971 Cl. 4.2-4.4, 5, 6.3)	P
	Affirmative statement together with safety sign placed in instructions for use if insufficient space on ME EQUIPMENT		N
	Specified colours in ISO 3864-1 used for safety signs..... :		N
	Safety notices include appropriate precautions or instructions on how to reduce RISK(S)		N
	Safety signs including any supplementary text or symbols described in instructions for use		N
	- and in a language acceptable to the intended OPERATOR		N
7.6	Symbols		P
7.6.1	Meanings of symbols used for marking described in instructions for use..... :	Refer to chapter 2.3 "Symbols" in user manual	P

IEC 60601-1			
Clause	Requirement + Test	Result - Remark	Verdict
7.6.3	Symbols used for controls and performance conform to the IEC or ISO publication where symbols are defined, as applicable		P
7.7	Colours of the insulation of conductors		N
7.7.1	PROTECTIVE EARTH CONDUCTOR identified by green and yellow insulation	No PROTECTIVE EARTH CONDUCTOR	N
7.7.2	Insulation on conductors inside ME EQUIPMENT forming PROTECTIVE EARTH CONNECTIONS identified by green and yellow at least at terminations		N
7.7.3	Green and yellow insulation identify only following conductors:		N
	– PROTECTIVE EARTH CONDUCTORS	No PROTECTIVE EARTH CONDUCTOR	N
	– conductors specified in 7.7.2		N
	– POTENTIAL EQUALIZATION CONDUCTORS	No POTENTIAL EQUALIZATION CONDUCTORS	N
	– FUNCTIONAL EARTH CONDUCTORS	No FUNCTIONAL EARTH CONDUCTORS	N
7.7.4	Neutral conductors of POWER SUPPLY CORDS are “light blue”	Powered by INTERNAL ELECTRICAL POWER SOURCE	N
7.7.5	Colours of conductors in POWER SUPPLY CORDS in accordance with IEC 60227-1 or IEC 60245-1	Powered by INTERNAL ELECTRICAL POWER SOURCE	N
7.8	Indicator lights and controls		N
7.8.1	Red indicator lights used only for Warning	No indicator lights	N
	Yellow indicator lights used only for Caution		N
	Green indicator lights used only for Ready for use		N
	Other colours: Meaning other than red, yellow, or green (colour, meaning)..... :		N
7.8.2	Red used only for emergency control	No emergency control	N
7.9	ACCOMPANYING DOCUMENTS		P
7.9.1	ME EQUIPMENT accompanied by documents containing instructions for use, and a technical description		P
	ACCOMPANYING DOCUMENTS identify ME EQUIPMENT by the following, as applicable:		P
	– Name or trade-name of MANUFACTURER and contact information for the RESPONSIBLE ORGANIZATION can be referred to	Refer chapter 6 “ Contact Information” in user manual	P
	– MODEL or TYPE REFERENCE	Refer chapter 5 “Applicable models” in user manual	P
	When ACCOMPANYING DOCUMENTS provided electronically, USABILITY ENGINEERING PROCESS includes instructions as to what is required in hard copy or as markings on ME EQUIPMENT	ACCOMPANYING DOCUMENTS is provided in written form only	N

IEC 60601-1			
Clause	Requirement + Test	Result - Remark	Verdict
	ACCOMPANYING DOCUMENTS specify special skills, training, and knowledge required of OPERATOR or RESPONSIBLE ORGANIZATION and environmental restrictions on locations of use		P
	ACCOMPANYING DOCUMENTS written at a level consistent with education, training, and other needs of individuals for whom they are intended		P
7.9.2	Instructions for use include the required information		P
7.9.2.1	– use of ME EQUIPMENT as intended by the MANUFACTURER:	Refer to chapter 2.2 “Application” in user manual	P
	– frequently used functions,	Refer to chapter 2.1 “Brief Device Description” in user manual	P
	– known contraindication(s) to use of ME EQUIPMENT	No contraindication	N
	- parts of the ME EQUIPMENT that are not serviced or maintained while in use with the patient	No such parts	N
	– name or trademark and address of the MANUFACTURER	Refer chapter 6 “ Contact Information” in user manual	P
	– MODEL OR TYPE REFERENCE	Refer chapter 5 “Applicable models” in user manual	P
	Instruction for use included the following when the PATIENT is an intended OPERATOR:		P
	– the PATIENT is an intended OPERATOR	Refer to chapter 2.1 “Brief Device Description” in user manual	P
	– warning against servicing and maintenance while the ME EQUIPMENT is in use	Refer to chapter 1.2 “Warnings” in user manual	P
	- functions the PATIENT can safely use and, where applicable, which functions the PATIENT cannot safely use; and	Refer to chapter 3 “Installation, Setup, and Operation” in user manual	P
	–maintenance the PATIENT can perform	Refer to chapter 4.1 “Maintenance and Preservation” in user manual	P
	Classifications as in Clause 6, all markings per Clause 7.2, and explanation of safety signs and symbols marked on ME EQUIPMENT	Refer to chapter 2.3 “Symbols” in user manual	P
	Instructions for use are in a language acceptable to the intended operator		P
7.9.2.2	Instructions for use include all warning and safety notices		P
	Warning statement for CLASS I ME EQUIPMENT included	Powered by INTERNAL ELECTRICAL POWER SOURCE	N
	Warnings regarding significant RISKS of reciprocal interference posed by ME EQUIPMENT during specific investigations or treatments	Refer to chapter 1.1 “Safety information” in the user manual	P

IEC 60601-1			
Clause	Requirement + Test	Result - Remark	Verdict
	Information on potential electromagnetic or other interference and advice on how to avoid or minimize such interference	Refer to chapter 1.1 "Safety information" in the user manual	P
	Warning statement for ME EQUIPMENT supplied with an integral MULTIPLE SOCKET-OUTLET provided	No integral MULTIPLE SOCKET-OUTLET	N
	The RESPONSIBLE ORGANIZATION is referred to this standard for the requirements applicable to ME SYSTEMS		P
7.9.2.3	Statement on ME EQUIPMENT for connection to a separate power supply provided in instructions	Not intended for connection to a separate power supply	N
7.9.2.4	Warning statement for mains- operated ME EQUIPMENT with additional power source not automatically maintained in a fully usable condition indicating the necessity for periodic checking or replacement of power source	Powered by INTERNAL ELECTRICAL POWER SOURCE	N
	RISK MANAGEMENT FILE assesses the RISK resulting from leakage of batteries : (ISO 14971 Cl. 4.2-4.4, 5, 6.3)	RMF Reference to specific RISKS: YMDK-RD-C101H1-0005/A0, YMDK-RD-C101H1-0002/A0, and YMDK-RD-C101H1-0007/A01 (ISO 14971 Cl. 4.2-4.4, 5, 6.3)	P
	Where the RISK is unacceptable, the IFU includes a warning to remove the battery if the ME EQUIPMENT is not likely to be used for some time :	Refer to chapter 1.2 "Warnings" in user manual	P
	Specifications of replaceable INTERNAL ELECTRICAL POWER SOURCE when provided :	Refer to chapter 2.4 "Specifications" in user manual	P
	Warning indicating ME EQUIPMENT must be connected to an appropriate power source when loss of power source..... would result in an unacceptable RISK..... :	No such RISK	N
7.9.2.5	Instructions for use include a description of ME EQUIPMENT, its functions, significant physical and performance characteristics together with the expected positions of OPERATOR, PATIENT, or other persons near ME EQUIPMENT in NORMAL USE	Refer to chapter 2.4 "Specifications" in user manual	P
	Information provided on materials and ingredients PATIENT or OPERATOR is exposed to	Refer to chapter 1.4 "Definitions and Symbols" in user manual	P
	Restrictions specified on other equipment or NETWORK/DATA COUPLINGS, other than those forming part of an ME SYSTEM, to which a SIGNAL INPUT/OUTPUT PART may be connected	No INPUT/OUTPUT PART	N
	APPLIED PARTS specified	Refer to chapter 2.4 "Specifications" in user manual	P
7.9.2.6	Information provided indicating where the installation instructions may be found or information on qualified personnel who can perform the installation	Refer to chapter 3 "Installation, Setup, and Operation" in user manual	P

IEC 60601-1			
Clause	Requirement + Test	Result - Remark	Verdict
7.9.2.7	Instructions provided indicating not to position ME EQUIPMENT to make it difficult to operate the disconnection device	Powered by INTERNAL ELECTRICAL POWER SOURCE	N
7.9.2.8	Necessary information provided for OPERATOR to bring ME EQUIPMENT into operation	Refer to chapter 3 "Installation, Setup, and Operation" in user manual	P
7.9.2.9	Information provided to operate ME EQUIPMENT		P
	Meanings of figures, symbols, warning statements, abbreviations and indicator lights described in instructions for use	Refer to chapter 3 "Installation, Setup, and Operation" in user manual	P
7.9.2.10	A list of all system messages, error messages, and fault messages provided with an explanation of messages including important causes and possible action(s) to be taken to resolve the problem indicated by the message	Refer to chapter 4.3 "Possible problems and effective solutions" in user manual	P
7.9.2.11	Information provided for the OPERATOR to safely terminate operation of ME EQUIPMENT	Refer to chapter 3 "Installation, Setup, and Operation" in user manual	P
7.9.2.12	Information provided on cleaning, disinfection, and sterilization methods, and applicable parameters that can be tolerated by ME EQUIPMENT parts or ACCESSORIES specified	Refer to chapter 1.4 "Definitions and Symbols" in user manual	P
	Components, ACCESSORIES or ME EQUIPMENT marked for single use, except when required by MANUFACTURER to be cleaned, disinfected, or sterilized prior to use	No single use parts	N
7.9.2.13	Instructions provided on preventive inspection, calibration, maintenance and its frequency	Refer to chapter 4.1 "Maintenance and Preservation in user manual	P
	Information provided for safe performance of routine maintenance necessary to ensure continued safe use of ME EQUIPMENT		P
	Parts requiring preventive inspection and maintenance to be performed by SERVICE PERSONNEL identified including periods of application		N
	Instructions provided to ensure adequate maintenance of ME EQUIPMENT containing rechargeable batteries to be maintained by anyone other than SERVICE PERSONNEL		N
7.9.2.14	A list of ACCESSORIES, detachable parts, and materials for use with ME EQUIPMENT provided		N
	Other equipment providing power to ME SYSTEM sufficiently described	Powered by INTERNAL ELECTRICAL POWER SOURCE	N
7.9.2.15	Disposal of waste products, residues, etc., and of ME EQUIPMENT and ACCESSORIES at the end of their EXPECTED SERVICE LIFE are identified in the instruction for use	Refer to chapter 1.2 "Warnings" in user manual	P

IEC 60601-1			
Clause	Requirement + Test	Result - Remark	Verdict
7.9.2.16	Instructions for use include information specified in 7.9.3 or identify where it can be found (e.g. in a service manual)	Refer to chapter 1.1 "Safety information" in the user manual	P
7.9.2.17	Instruction for use for ME EQUIPMENT emitting radiation for medical purposes, indicate the nature, type, intensity and distribution of this radiation	No such function	N
7.9.2.18	The instructions for use for ME EQUIPMENT or ACCESSORIES supplied sterile indicate that they have been sterilized and the method of sterilization	No sterilization	N
	The instructions for use indicate the necessary instructions in the event of damage to the sterile packaging, and where appropriate, details of the appropriate methods of re-sterilization		N
7.9.2.19	The instructions for use contain a unique version identifier	Refer to the cover of user manual	P
7.9.3	Technical description		P
7.9.3.1	All essential data provided for safe operation, transport, storage, and measures or conditions necessary for installing ME EQUIPMENT, and preparing it for use	Refer to chapter 2.4 "Specifications" in user manual	P
	Technical description separable from instructions for use contains required information, as follows		N
	– all applicable classifications in Clause 6, warning and safety notices, and explanation of safety signs marked on ME EQUIPMENT		N
	– a brief description of the ME EQUIPMENT, how the ME EQUIPMENT functions and its significant physical and performance characteristics; and		N
	a unique version identifier		N
	MANUFACTURER'S optional requirements for minimum qualifications of SERVICE PERSONNEL documented in technical description		N
7.9.3.2	The technical description contains the following required information		N
	–type and full rating of fuses used in SUPPLY MAINS external to PERMANENTLY INSTALLED ME EQUIPMENT	No permanently installed me equipment	N
	– a statement for ME EQUIPMENT with a non-DETACHABLE POWER SUPPLY CORD if POWER SUPPLY CORD is replaceable by SERVICE PERSONNEL, and	No non-detachable power supply cord	N
	– instructions for correct replacement of interchangeable or detachable parts specified by MANUFACTURER as replaceable by SERVICE PERSONNEL, and	No such parts	N
	RISK MANAGEMENT FILE includes an assessment to determine if replacement of components results in any unacceptable RISKS		N
	(ISO 14971 Cl. 4.2-4.4, 5, 6.2-6.5)		

IEC 60601-1			
Clause	Requirement + Test	Result - Remark	Verdict
	– warnings identifying nature of HAZARD when replacement of a component could result in an unacceptable RISK, and when replaceable by SERVICE PERSONNEL all information necessary to safely replace the component		N
7.9.3.3	Technical description indicates, MANUFACTURER will provide circuit diagrams, component part lists, descriptions, calibration instructions to assist to SERVICE PERSONNEL in parts repair	Refer to chapter 1.1 “Safety information” in the user manual	P
7.9.3.4	Means used to comply with requirements of 8.11.1 clearly identified in technical description		N

8	PROTECTION AGAINST ELECTRICAL HAZARDS FROM ME EQUIPMENT		P
8.1	Limits specified in Clause 8.4 not exceeded for ACCESSIBLE PARTS and APPLIED PARTS in NORMAL or SINGLE FAULT CONDITIONS		P
	RISK MANAGEMENT FILE identifies conductors and connectors where breaking free results in a HAZARDOUS SITUATION..... : (ISO 14971 Cl. 4.3)	RMF Reference to specific RISKS: YMDK-RD-C101H1-0002/A0 (ISO 14971 Cl. 4.3)	P
8.2	Requirements related to power sources		N
8.2.1	Connection to a separate power source		N
	When ME EQUIPMENT specified for connection to a separate power source other than SUPPLY MAINS, separate power source considered as part of ME EQUIPMENT or combination considered as an ME SYSTEM	Not intended for connection to a separate power source	N
	Tests performed with ME EQUIPMENT connected to separate power supply when one specified		N
	When a generic separate power supply specified, specification in ACCOMPANYING DOCUMENTS examined		N
8.2.2	Connection to an external d.c. power source		N
	No HAZARDOUS SITUATION as described in 13.1 developed when a connection with wrong polarity made for ME EQUIPMENT from an external d.c. source	Not intended to be connected to an external d.c. power source	N
	ME EQUIPMENT connected with correct polarity maintained BASIC SAFETY and ESSENTIAL PERFORMANCE		N
	Protective devices that can be reset by anyone without a TOOL returns to NORMAL CONDITION on reset		N
8.3	Classification of APPLIED PARTS		P
	a) APPLIED PART specified in ACCOMPANYING DOCUMENTS as suitable for DIRECT CARDIAC APPLICATION IS TYPE CF		N

IEC 60601-1			
Clause	Requirement + Test	Result - Remark	Verdict
	b) An APPLIED PART provided with a PATIENT CONNECTION intended to deliver electrical energy or an electrophysiological signal to or from PATIENT is TYPE BF or CF APPLIED PART		P
	c) An APPLIED PART not covered by a) or b) is a TYPE B, BF, or CF		N
8.4	Limitation of voltage, current or energy		P
8.4.2	ACCESSIBLE PARTS and APPLIED PARTS		P
	a) Currents from, to, or between PATIENT CONNECTIONS did not exceed limits for PATIENT LEAKAGE CURRENT & PATIENT AUXILIARY CURRENT . :	See appended Table 8.7	P
	b) LEAKAGE CURRENTS from, to, or between ACCESSIBLE PARTS did not exceed limits for TOUCH CURRENT..... :	See appended Table 8.7	P
	c) Limits specified in b) not applied to parts when probability of a connection to a PATIENT, directly or through body of OPERATOR, is negligible in NORMAL USE, and the OPERATOR is appropriately instructed	No such parts	N
	Voltage to earth or to other ACCESSIBLE PARTS did not exceed 42.4 V peak a.c. or 60 V d.c. for above parts in NORMAL or single fault condition (V a.c. or d.c.)..... :		N
	Energy did not exceed 240 VA for longer than 60 s or stored energy available did not exceed 20 J at a potential of 2 V or more (VA or J)..... :		N
	d) Voltage and energy limits specified in c) above also applied to the following:		N
	– internal parts touchable by test pin in Fig 8 inserted through an opening in an ENCLOSURE; and	No opening	N
	– internal parts touchable by a metal test rod with a diameter of 4 mm and a length 100 mm, inserted through any opening on top of ENCLOSURE or through any opening provided for adjustment of pre-set controls by RESPONSIBLE ORGANIZATION in NORMAL USE using a TOOL		N
	Test pin or the test rod inserted through relevant openings with minimal force of no more than 1 N		N
	Test rod inserted in every possible position through openings provided for adjustment of pre-set controls that can be adjusted in NORMAL USE, with a force of 10 N	No such pre-set controls	N
	Test repeated with a TOOL specified in instructions for use		N
	Test rod freely and vertically suspended through openings on top of ENCLOSURE		N

IEC 60601-1			
Clause	Requirement + Test	Result - Remark	Verdict
	e) Devices used to de-energize parts when an ACCESS COVER opened without a TOOL gives access to parts at voltages above levels permitted by this Clause comply with 8.11.1 for mains isolating switches and remain effective in SINGLE FAULT CONDITION	No such devices used	N
	A TOOL is required when it is possible to prevent the devices from operating		N
8.4.3	Worst case voltage between pins of plug and between either supply pin and ENCLOSURE did not exceed 60 V one sec after disconnecting the plug of ME EQUIPMENT or its parts (V)	Powered by INTERNAL ELECTRICAL POWER SOURCE	N
	When voltage exceeded 60 V, calculated or measured stored charge didn't exceed 45 μ C.....		N
8.4.4	Residual voltage of conductive parts of capacitive circuits, having become accessible after ME EQUIPMENT was de-energized after removal of ACCESS COVERS, didn't exceed 60V or calculated stored charge didn't exceed 45 μ C.....	Powered by INTERNAL ELECTRICAL POWER SOURCE	N
	A device manually discharging capacitors used when automatic discharging was not possible and ACCESS COVERS could be removed only with aid of a TOOL		N
	Capacitor(s) and connected circuitry marked with symbol 24 of Table D.1, and manual discharging device specified in technical description.....		N
8.5	Separation of parts		P
8.5.1	MEANS OF PROTECTION (MOP)		P
8.5.1.1	Two MEANS of PROTECTION provided for ME EQUIPMENT to prevent APPLIED and other ACCESSIBLE PARTS from exceeding limits in 8.4	See insulation diagram	P
	Varnishing, enamelling, oxidation, and similar protective finishes and coatings with sealing compounds re-plasticizing at temperatures expected during operation and sterilization disregarded as MEANS OF PROTECTION		N
	Components and wiring forming a MEANS OF PROTECTION comply with 8.10	See Appended Table 8.10	P
8.5.1.2	MEANS OF PATIENT PROTECTION (MOPP)		P
	Solid insulation forming a MEANS OF PATIENT PROTECTION complied with dielectric strength test:	See appended Table 8.8.3	P
	CREEPAGE and CLEARANCES forming a MEANS OF PATIENT PROTECTION complied with Table 12	Refer to Insulation Diagram Table	P
	PROTECTIVE EARTH CONNECTIONS forming a MEANS OF PATIENT PROTECTION complied with Cl. 8.6	No PROTECTIVE EARTH CONNECTIONS	N
	Y1 or Y2 capacitor complying with standard IEC 60384-14 considered one MEANS OF PATIENT PROTECTION	No such Y capacitor used	N

IEC 60601-1			
Clause	Requirement + Test	Result - Remark	Verdict
	Single Y1 capacitor used for two MEANS OF PATIENT PROTECTION when the working voltage is less than 42,4 V peak a.c. or 60 V d.c. :	No such Y capacitor used	N
	Two capacitors used in series, each RATED for total WORKING VOLTAGE across the pair and have the same NOMINAL capacitance		N
	Voltage _{Total Working} (V) and C _{Nominal} (μF) :		—
8.5.1.3	MEANS OF OPERATOR PROTECTION (MOOP)		P
	Solid insulation forming a MEANS OF OPERATOR PROTECTION complied with:		P
	– dielectric strength test :	See appended Table 8.8.3	P
	– requirements of IEC 60950-1 for INSULATION CO-ORDINATION		N
	CREEPAGE and CLEARANCES forming a MEANS OF OPERATOR PROTECTION complied with:		P
	– limits of Tables 13 to 16 (inclusive); or		P
	– requirements of IEC 60950-1 for INSULATION CO-ORDINATION		N
	PROTECTIVE EARTH CONNECTIONS forming a MEANS OF OPERATOR PROTECTION complied with Cl. 8.6	No PROTECTIVE EARTH CONNECTIONS	N
	– or with requirements and tests of IEC 60950-1 for protective earthing :		N
	A Y2 (IEC 60384-14) capacitor is considered one MEANS OF OPERATOR PROTECTION :	No such Y capacitor used	N
	A Y1 (IEC 60384-14) capacitor is considered two MEANS OF OPERATOR PROTECTION :	No such Y capacitor used	N
	Two capacitors used in series each RATED for total WORKING VOLTAGE across the pair and have the same NOMINAL capacitance		N
	Voltage _{Total Working} (V) and C _{Nominal} (μF) :		—
	Points and applied parts at which impedances of components, CREEPAGE, CLEARANCES, PROTECTIVE EARTH CONNECTIONS or insulation, prevent ACCESSIBLE PARTS from exceeding limits in 8.4 were examined whether a failure at any of these points is to be regarded as a NORMAL or SINGLE FAULT CONDITION		P
	A MEANS OF PROTECTION protecting APPLIED PARTS, or parts identified by 4.6 as parts subject to the same requirements, considered MEANS OF PATIENT PROTECTION :		P
	A MEANS OF PROTECTION protecting other parts considered MEANS OF OPERATOR PROTECTION :		P
8.5.2	Separation of PATIENT CONNECTIONS		P

IEC 60601-1			
Clause	Requirement + Test	Result - Remark	Verdict
8.5.2.1	PATIENT CONNECTIONS of F-TYPE APPLIED PART separated from all other parts by equivalent to one MEANS OF PATIENT PROTECTION for a WORKING VOLTAGE equal to the MAX. MAINS VOLTAGE..... :	250V	P
	Separation requirement not applied between multiple functions of a single F-TYPE APPLIED PART	Only one applied part	N
	PATIENT CONNECTIONS treated as one APPLIED PART in the absence of electrical separation between PATIENT CONNECTIONS of same or another function		N
	MANUFACTURER has defined if multiple functions are to be considered as all within one APPLIED PART or as multiple APPLIED PARTS		N
	Classification as TYPE BF, CF, or DEFIBRILLATION-PROOF applied to one entire APPLIED PART		P
	LEAKAGE CURRENT tests conducted per 8.7.4..... :	See appended Table 8.7	P
	Dielectric strength test conducted per 8.8.3	See appended Table 8.8.3	P
	CREEPAGE and CLEARANCES measured	Refer to Insulation Diagram	P
	A protective device connected between PATIENT CONNECTIONS of an F-TYPE APPLIED PART and ENCLOSURE to protect against excessive voltages did not operate below 500 V r.m.s	No such protective device	N
8.5.2.2	PATIENT CONNECTIONS of a TYPE B APPLIED PART not PROTECTIVELY EARTHED are separated by one MEANS OF PATIENT PROTECTION from metal ACCESSIBLE PARTS not PROTECTIVELY EARTHED..... :		N
	– except when metal ACCESSIBLE PART is physically close to APPLIED PART and can be regarded as a part of APPLIED PART; and		N
	– RISK that metal ACCESSIBLE PART will make contact with a source of voltage or LEAKAGE CURRENT above permitted limits is acceptably low		N
	LEAKAGE CURRENT tests conducted per 8.7.4..... :		N
	Dielectric strength test conducted per 8.8.3		N
	Relevant CREEPAGE and CLEARANCES measured		N
	RISK MANAGEMENT FILE includes an assessment of the RISK of metal ACCESSIBLE PARTS contacting a source of voltage or LEAKAGE CURRENT above the limits.....: (ISO 14971 Cl. 4.2-4.4,5)		N
8.5.2.3	A connector on a PATIENT lead or PATIENT cable located at the end of the lead or cable remote from PATIENT, with conductive part not separated from all PATIENT CONNECTIONS by one MEANS OF PATIENT PROTECTION for a WORKING VOLTAGE equal to MAXIMUM MAINS VOLTAGE		N
	- cannot be connected to earth or hazardous voltage while the PATIENT CONNECTIONS are in contact with PATIENT..... :		N

IEC 60601-1			
Clause	Requirement + Test	Result - Remark	Verdict
	– conductive part of connector not separated from all PATIENT CONNECTIONS did not come into contact with a flat conductive plate of not less than 100 mm diameter		N
	– CLEARANCE between connector pins and a flat surface is at least 0.5 mm		N
	– conductive part pluggable into a mains socket protected from making contact with parts at MAINS VOLTAGE by insulation with a CREEPAGE DISTANCE of at least 1.0 mm, a 1500 V dielectric strength and complying with 8.8.4.1		N
	– required test finger did not make electrical contact with conductive part when applied against access openings with a force of 10 N,		N
	Test finger test (10 N)		N
	Except when RISK MANAGEMENT PROCESS includes an assessment of RISKS resulting from contact with objects other than mains sockets or flat surfaces . : (ISO 14971 Cl. 4.2-4.4, 5)		N
8.5.4	WORKING VOLTAGE		P
	– Input supply voltage to ME EQUIPMENT was RATED voltage or voltage within RATED range resulting in highest measured value (V)	DC 3V	P
	– WORKING VOLTAGE for d.c. voltages with superimposed ripple was average value when peak-to-peak ripple less than 10% of average value or peak voltage when peak-to-peak ripple exceeding 10% of average value (V)		N
	– WORKING VOLTAGE for each MEANS OF PROTECTION forming DOUBLE INSULATION was voltage DOUBLE INSULATION, as a whole, subjected to (V)	See Insulation Diagram and Insulation Table	P
	– Intentional or accidental earthing of PATIENT regarded as a NORMAL CONDITION for WORKING VOLTAGE involving a PATIENT CONNECTION not connected to earth		P
	– WORKING VOLTAGE between PATIENT CONNECTIONS of an F-TYPE APPLIED PART and ENCLOSURE was highest voltage appearing across insulation in NORMAL USE including earthing of any part of APPLIED PART (V)	250	P
	– WORKING VOLTAGE for DEFIBRILLATION-PROOF APPLIED PARTS determined disregarding possible presence of defibrillation voltages		N
	– WORKING VOLTAGE was equal to resonance voltage in case of motors provided with capacitors between the point where a winding and a capacitor are connected together and a terminal for external conductors (V)		N
8.5.5	DEFIBRILLATION-PROOF APPLIED PARTS		N

IEC 60601-1			
Clause	Requirement + Test	Result - Remark	Verdict
8.5.5.1	Classification "DEFIBRILLATION-PROOF APPLIED PART" applied to one APPLIED PART in its entirety	No DEFIBRILLATION-PROOF APPLIED PART	N
	Isolation of PATIENT CONNECTIONS of a DEFIBRILLATION-PROOF APPLIED PART from other parts of ME EQUIPMENT accomplished as follows:		N
	a) No hazardous electrical energies appear during a discharge of cardiac defibrillator		N
	b) ME EQUIPMENT complied with relevant requirements of this standard, providing BASIC SAFETY and ESSENTIAL PERFORMANCE following exposure to defibrillation voltage, and recovery time stated in ACCOMPANYING DOCUMENTS		N
8.5.5.2	Means provided to limit energy delivered to a 100 Ω load		N
8.6	Protective and functional earthing and potential equalization of ME EQUIPMENT		N
8.6.1	Requirements of 8.6.2 to 8.6.8 applied		N
	Parts complying with IEC 60950-1 for protective earthing and serving as MEANS OF OPERATOR PROTECTION but not PATIENT PROTECTION exempted from requirements of 8.6.2 to 8.6.8	No protective earthing	N
8.6.2	PROTECTIVE EARTH TERMINAL is suitable for connection to an external protective earthing system by a PROTECTIVE EARTH CONDUCTOR in a POWER SUPPLY CORD and a suitable plug or by a FIXED PROTECTIVE EARTH CONDUCTOR		N
	Clamping means of PROTECTIVE EARTH TERMINAL of ME EQUIPMENT for FIXED supply conductors or POWER SUPPLY CORDS comply with 8.11.4.3, and cannot be loosened without TOOL		N
	Screws for internal PROTECTIVE EARTH CONNECTIONS completely covered or protected against accidental loosening from outside		N
	Earth pin of APPLIANCE INLET forming supply connection to ME EQUIPMENT regarded as PROTECTIVE EARTH TERMINAL		N
	PROTECTIVE EARTH TERMINAL not used for mechanical connection between different parts of ME EQUIPMENT or securing components not related to protective or functional earthing		N
8.6.3	PROTECTIVE EARTH CONNECTION not used for a moving part,		N
	except when MANUFACTURER demonstrated in RISK MANAGEMENT FILE connection will remain reliable during EXPECTED SERVICE LIFE		N
	(ISO 14971 Cl. 4.2-4.4, 5, 6.2-6.5)		
8.6.4	a) PROTECTIVE EARTH CONNECTIONS carried fault currents reliably and without excessive voltage drop		N

IEC 60601-1			
Clause	Requirement + Test	Result - Remark	Verdict
	b) Allowable TOUCH CURRENT and PATIENT LEAKAGE CURRENT in SINGLE FAULT CONDITION were not exceeded, when impedance of PROTECTIVE EARTH CONNECTIONS exceeded values in 8.6.4 a) and Table 8.6.4, due to limited current capability of relevant circuits..... :		N
8.6.5	Surface coatings		N
	Poorly conducting surface coatings on conductive elements removed at the point of contact		N
	Coating not removed when requirements for impedance and current-carrying capacity met		N
8.6.6	Plugs and sockets		N
	PROTECTIVE EARTH CONNECTION where connection between SUPPLY MAINS and ME EQUIPMENT or between separate parts of ME EQUIPMENT made via a plug and socket was made before and interrupted after supply connections		N
	- applied also where interchangeable parts are PROTECTIVELY EARTHED		N
8.6.7	Terminal for connection of a POTENTIAL EQUALIZATION CONDUCTOR		N
	- Terminal is accessible to OPERATOR with ME EQUIPMENT in any position of NORMAL USE	No POTENTIAL EQUALIZATION CONDUCTOR	N
	-accidental disconnection avoided in NORMAL USE		N
	- Terminal allows conductor to be detached without a TOOL		N
	- Terminal not used for a PROTECTIVE EARTH CONNECTION		N
	- Terminal marked with symbol 8 of Table D.1		N
	- Instructions for use contain information on function and use of POTENTIAL EQUALIZATION CONDUCTOR together with a reference to requirements of this standard		N
	POWER SUPPLY CORD does not incorporate a POTENTIAL EQUALIZATION CONDUCTOR		N
8.6.8	FUNCTIONAL EARTH TERMINAL not used to provide a PROTECTIVE EARTH CONNECTION	No FUNCTIONAL EARTH TERMINAL	N
8.6.9	Class II ME EQUIPMENT		N
	Third conductor of POWER SUPPLY CORD connected to protective earth contact of MAINS PLUG provided with CLASS II ME EQUIPMENT with isolated internal screens used as functional earth connection to the screen's FUNCTIONAL EARTH TERMINAL, coloured green and yellow	Powered by INTERNAL ELECTRICAL POWER SOURCE	N
	ACCOMPANYING DOCUMENTS include a statement that the third conductor in the POWER SUPPLY CORD is only a functional earth.		N

IEC 60601-1			
Clause	Requirement + Test	Result - Remark	Verdict
	Two MEANS OF PROTECTION provided between insulation of internal screens and all internal wiring connected to them and ACCESSIBLE PARTS		N
8.7	LEAKAGE CURRENTS and PATIENT AUXILIARY CURRENTS		P
8.7.1	a) Electrical isolation providing protection against electric shock limits currents to values in 8.7.3 :	See appended Tables 8.7	P
	b) Specified values of EARTH LEAKAGE, TOUCH, PATIENT LEAKAGE, and PATIENT AUXILIARY CURRENTS applied in combination of conditions in appended Table 8.7	See appended Tables 8.7	P
8.7.2	Allowable values specified in 8.7.3 applied under SINGLE FAULT CONDITIONS of 8.1 b), except		P
	– where insulation used in conjunction with a PROTECTIVE EARTH CONNECTION, insulation short circuited only under conditions in 8.6.4 b)		N
	– the only SINGLE FAULT CONDITION for EARTH LEAKAGE CURRENT was interruption of one supply conductor at a time		N
	– LEAKAGE CURRENTS and PATIENT AUXILIARY CURRENT not measured in SINGLE FAULT CONDITION of short circuiting of one constituent part of DOUBLE INSULATION		P
	SINGLE FAULT CONDITIONS not applied at same time as special test conditions of MAXIMUM MAINS VOLTAGE on APPLIED PARTS and non-PROTECTIVELY EARTHED parts of ENCLOSURE		P
8.7.3	Allowable Values		P
	a) Allowable values in 8.7.3 b), c), and d) measured based on, and are relative to currents in Fig 12 a), or by a device measuring frequency contents of currents as in Fig 12 b)	See appended Table 8.7	P
	b) Allowable values of PATIENT LEAKAGE and AUXILIARY CURRENTS are according to Tables 3 & 4, and values of a.c. are relative to currents having a frequency not less than 0.1Hz	See appended Table 8.7	P
	c) TOUCH CURRENT did not exceed 100 μ A in NORMAL CONDITION and 500 μ A in SINGLE FAULT CONDITION (I_{TNC} , I_{TSFC})..... :	See appended Table 8.7	P
	d) EARTH LEAKAGE CURRENT did not exceed 5 mA in NORMAL CONDITION and 10 mA in SINGLE FAULT CONDITION (I_{ENC} , I_{ESFC})	No PROTECTIVE EARTH CONNECTION	N
	Higher values of EARTH LEAKAGE CURRENT permitted for PERMANENTLY INSTALLED ME EQUIPMENT connected to a supply circuit supplying only this ME EQUIPMENT according to local regulations or IEC 60364-7-710	No PERMANENTLY INSTALLED ME EQUIPMENT	N

IEC 60601-1			
Clause	Requirement + Test	Result - Remark	Verdict
	e) LEAKAGE CURRENTS, regardless of waveform and frequency, did not exceed 10 mA r.m.s. in NORMAL or in SINGLE FAULT CONDITION (measured with a non-frequency-weighted device..... :		N
	f) LEAKAGE CURRENTS flowing in a FUNCTIONAL EARTH CONDUCTOR in a non-PERMANENTLY INSTALLED ME EQUIPMENT are 5 mA in NORMAL CONDITION, 10 mA in SINGLE FAULT CONDITION..... :	No functional earth conductor	N
8.7.4	LEAKAGE and PATIENT AUXILIARY CURRENTS measurements		N
8.8	Insulation		P
8.8.1	Insulation relied on as MEANS OF PROTECTION, including REINFORCED INSULATION subjected to testing		P
	Insulation exempted from test (complies with clause 4.8)		N
	Insulation forming MEANS OF OPERATOR PROTECTION and complying with IEC 60950-1 for INSULATION CO-ORDINATION not tested as in 8.8		N
8.8.2	Distance through solid insulation or use of thin sheet material		N
	Solid insulation forming SUPPLEMENTARY or REINFORCED INSULATION for a PEAK WORKING VOLTAGE greater than 71 V provided with:	Not greater than 71 V	N
	a) 0.4 mm, min, distance through insulation, or		N
	b) does not form part of an ENCLOSURE and not subject to handling or abrasion during NORMAL USE, and comprised of:		N
	– at least two layers of material, each passed the appropriate dielectric strength test		N
	– or three layers of material, for which all combinations of two layers together passed the appropriate dielectric strength test		N
	Dielectric strength test for one or two layers was same as for one MEANS OF PROTECTION for SUPPLEMENTARY INSULATION		N
	Dielectric strength test for one or two layers was same as for two MEANS OF PROTECTION for REINFORCED INSULATION		N
	BASIC, SUPPLEMENTARY, and REINFORCED INSULATION required between windings of wound components separated by interleaved insulation complying with a) or b), or both, except when		N
	c) Wire with solid insulation, other than solvent based enamel, complying with a)		N
	d) Wire with multi-layer extruded or spirally wrapped insulation complying with b) and complying with Annex L		N

IEC 60601-1			
Clause	Requirement + Test	Result - Remark	Verdict
	e) Finished wire with spirally wrapped or multi-layer extruded insulation, complying with Annex L		N
	– BASIC INSULATION: minimum two wrapped layers or one extruded layer		N
	– SUPPLEMENTARY INSULATION: minimum two layers, wrapped or extruded		N
	– REINFORCED INSULATION: minimum three layers, wrapped or extruded		N
	In d) and e), for spirally wrapped insulation with CREEPAGE DISTANCES between layers less than in Table 12 or 16 (Pollution Degree 1) depending on type of insulation, path between layers sealed as a cemented joint in 8.9.3.3 and test voltages of TYPE TESTS in L.3 equal 1.6 times of normal values		N
	Protection against mechanical stress provided where two insulated wires or one bare and one insulated wire are in contact inside wound component, crossing at an angle between 45° and 90° and subject to winding tension		N
	Finished component complied with routine dielectric strength tests of 8.8.3		N
	Tests of Annex L not repeated since material data sheets confirm compliance		N
8.8.3	Dielectric Strength		P
	Solid insulating materials with a safety function withstood dielectric strength test voltages	See appended Table 8.8.3	P
8.8.4	Insulation other than wire insulation		P
8.8.4.1	Resistance to heat retained by all insulation and insulating partition walls during EXPECTED SERVICE LIFE of ME EQUIPMENT		P
	ME EQUIPMENT and design documentation examined	Me equipment and material inspected	P
	RISK MANAGEMENT FILE examined in conjunction with resistance to moisture, dielectric strength, and mechanical strength tests	RMF Reference to specific RISKS: YMDK-RD-C101H1-0005/A0, YMDK-RD-C101H1-0002/A0, and YMDK-RD-C101H1-0007/A01 (ISO 14971 Cl. 4.2-4.4, 5, 6.2-6.5)	P
	Satisfactory evidence of compliance provided by manufacturer for resistance to heat		N
	Tests conducted in absence of satisfactory evidence for resistance to heat	See appended Table 8.8.4.1	P
	a) ENCLOSURE and other external parts of insulating material, except insulation of flexible cords and parts of ceramic material, subjected to ball-pressure test using Fig 21 apparatus	See appended Table 8.8.4.1	P

IEC 60601-1			
Clause	Requirement + Test	Result - Remark	Verdict
	b) Parts of insulating material supporting uninsulated parts of MAINS PART subjected to ball-pressure test in a), except at $125\text{ °C} \pm 2\text{ °C}$ or ambient indicated in technical description $\pm 2\text{ °C}$ plus temperature rise determined during test of 11.1 of relevant part, if higher (°C)		N
	Test not performed on parts of ceramic material, insulating parts of commutators, brush-caps, and similar, and on coil formers not used as REINFORCED INSULATION		N
8.8.4.2	Resistance to environmental stress		P
	Insulating characteristics and mechanical strength of all MEANS OF PROTECTION not likely to be impaired by environmental stresses including deposition of dirt resulting from wear of parts within EQUIPMENT, potentially reducing CREEPAGE and CLEARANCES below 8.9		P
	Ceramic and similar materials not tightly sintered, and beads alone not used as SUPPLEMENTARY or REINFORCED INSULATION	No such materials used	N
	Insulating material with embedded heating conductors considered as one MEANS OF PROTECTION but not two MEANS OF PROTECTION		N
	Parts of natural latex rubber aged by suspending samples freely in an oxygen cylinder containing commercial oxygen to a pressure of $2.1\text{ MPa} \pm 70\text{ kPa}$, with an effective capacity of at least 10 times volume of samples	No natural latex rubber used	N
	There were no cracks visible to naked eyes after samples kept in cylinder at $70\text{ °C} \pm 2\text{ °C}$ for 96h, and afterwards, left at room temperature for at least 16h		N
8.9	CREEPAGE DISTANCES and AIR CLEARANCES		P
8.9.1.1	CREEPAGE DISTANCES and AIR CLEARANCES are equal to or greater than values in Tables 12 to 16 (inclusive).....	Refer to Insulation Diagram	P
8.9.1.15	CREEPAGE DISTANCES and AIR CLEARANCES for DEFIBRILLATION-PROOF APPLIED PARTS are 4 mm or more to meet 8.5.5.1		N
8.9.2	a) Short circuiting of each single one of CREEPAGE DISTANCES and CLEARANCES in turn did not result in a HAZARDOUS SITUATION , min CREEPAGE and CLEARANCES not applied.....		N
8.9.3	Spaces filled by insulating compound		N
8.9.3.1	Only solid insulation requirements applied where distances between conductive parts filled with insulating compound	No such space	N
	Thermal cycling, humidity preconditioning, and dielectric strength tests		N

IEC 60601-1			
Clause	Requirement + Test	Result - Remark	Verdict
8.9.3.2	For insulating compound forming solid insulation between conductive parts, a single sample subjected to thermal cycling PROCEDURE of 8.9.3.4 followed by humidity preconditioning per 5.7 (for 48 hours), followed by dielectric strength test (cl. 8.8.3 at 1,6 x test voltage)		N
	Cracks or voids in insulating compound affecting homogeneity of material didn't occur		N
8.9.3.3	Where insulating compound forms a cemented joint with other insulating parts, three samples tested for reliability of joint		N
	A winding of solvent-based enamelled wire replaced for the test by a metal foil or by a few turns of bare wire placed close to cemented joint, and three samples tested as follows:		N
	– One sample subjected to thermal cycling PROCEDURE of 8.9.3.4, and immediately after the last period at highest temperature during thermal cycling followed by dielectric strength test of cl. 8.8.3 at 1.6 x the test voltage		N
	– The other two samples subjected to humidity preconditioning of 5.7, except for 48 hours only followed by a dielectric strength test of cl. 8.8.3 at 1.6 times the test voltage		N
8.10	Components and wiring		P
8.10.1	Components of ME EQUIPMENT likely to result in an unacceptable RISK by their movements mounted securely.....	Me equipment is inspected and all the components are mounted securely	P
	RISK MANAGEMENT FILE includes an assessment of RISKS related to unwanted movement of components	RMF Reference to specific RISKS: YMDK-RD-C101H1-0005/A0, YMDK-RD-C101H1-0002/A0, and YMDK-RD-C101H1-0007/A01 (ISO 14971 Cl. 4.2-4.4, 5, 6.2-6.5)	P
8.10.2	Conductors and connectors of ME EQUIPMENT adequately secured or insulated to prevent accidental detachment.....	Conductors and connectors are adequately secured	P
	Stranded conductors are not solder-coated when secured by clamping means to prevent HAZARDOUS SITUATIONS		P
8.10.3	Interconnecting flexible cords detachable without a TOOL used provided with means for connection to comply with requirements for metal ACCESSIBLE PARTS when a connection is loosened or broken ...		N
8.10.4	Cord-connected HAND-HELD parts and cord-connected foot-operated control devices		N

IEC 60601-1			
Clause	Requirement + Test	Result - Remark	Verdict
8.10.4.1	Control devices of ME EQUIPMENT and their connection cords contain only conductors and components operating at 42.4 V peak a.c., max, or 60 V d.c. in circuits isolated from MAINS PART by two MEANS OF PROTECTION	No cord-connected HAND-HELD parts and cord-connected foot-operated control devices	N
8.10.4.2	Connection and anchorage of a flexible cord to a HAND-HELD or foot-operated control device of ME EQUIPMENT, at both ends of the cable to the control device, complies with the requirements for POWER SUPPLY CORDS in Cl. 8.11.3		N
	Other HAND-HELD parts, if disturbance or breaking of one or more of the connections could result in a HAZARDOUS SITUATION, also comply with tests of Cl. 8.11.3		N
8.10.5	Mechanical protection of wiring		P
	a) Internal cables and wiring adequately protected against contact with a moving part or from friction at sharp corners and edges	Me equipment is inspected and internal cables and wiring are adequately protected	P
	b) Wiring, cord forms, or components are not likely to be damaged during assembly or during opening or closing of ACCESS COVERS		P
8.10.6	Guiding rollers prevent bending of movable insulated conductors around a radius of less than five times the outer diameter of the lead	No guiding rollers	N
8.10.7	a) Insulating sleeve adequately secured	No insulating sleeve	N
	b) Sheath of a flexible cord not used as a MEANS OF PROTECTION inside ME EQUIPMENT when it is subject to mechanical or thermal stresses beyond its RATED characteristics	No such sheath	N
	c) Insulated conductors of ME EQUIPMENT subject to temperatures exceeding 70 °C	<70 °C	N
8.11	MAINS PARTS, components and layout		N
8.11.1	a) ME EQUIPMENT provided with means of electrically isolating its circuits from SUPPLY MAINS simultaneously on all poles	Powered by INTERNAL ELECTRICAL POWER SOURCE	N
	PERMANENTLY INSTALLED ME EQUIPMENT connected to a poly-phase SUPPLY MAINS equipped with a device not interrupting neutral conductor, provided local installation conditions prevent voltage on neutral conductor from exceeding limits in 8.4.2 c)		N
	PERMANENTLY INSTALLED ME EQUIPMENT provided with means to isolate its circuits electrically from the SUPPLY MAINS are capable of being locked in the off position		N
	- the isolation device specified in the ACCOMPANYING DOCUMENTS		N
	b) Means of isolation incorporated in ME EQUIPMENT, or if external, described in technical description		N

IEC 60601-1			
Clause	Requirement + Test	Result - Remark	Verdict
	c) A SUPPLY MAINS switch used to comply with 8.11.1 a) complies with CREEPAGE / CLEARANCES for a MAINS TRANSIENT VOLTAGE of 4 kV		N
	d) A SUPPLY MAINS switch not incorporated in a POWER SUPPLY CORD or external flexible lead		N
	e) Actuator of a SUPPLY MAINS switch used to comply with 8.11.1 a) complies with IEC 60447		N
	f) A suitable plug device used in non-PERMANENTLY INSTALLED ME EQUIPMENT with no SUPPLY MAINS SWITCH.....		P
	g) A fuse or a semiconductor device not used as an isolating means		P
	h) ME EQUIPMENT not provided with a device causing disconnection of ME EQUIPMENT from SUPPLY MAINS by producing a short circuit resulting in operation of an overcurrent protection device		N
	i) Parts within ENCLOSURE of ME EQUIPMENT with a circuit > 42.4 V peak a.c. or 60 V d.c. that cannot be disconnected from its supply by an external switch or a plug device accessible at all times is protected against touch even after opening ENCLOSURE by an additional covering		N
	A clear warning notice is marked on outside of ME EQUIPMENT to indicate it exceeds allowable touch voltage		N
	For a part that could not be disconnected from supply by an external switch or a plug device accessible at all times, the required cover or warning notice complied with this clause		N
	Standard test finger applied		N
8.11.2	MULTIPLE SOCKET-OUTLETS integral with ME EQUIPMENT complied with 16.2 d), second dash; and 16.9.2		N
8.11.3	POWER SUPPLY CORDS		N
8.11.3.1	MAINS PLUG not fitted with more than one POWER SUPPLY CORD		N
8.11.3.2	POWER SUPPLY CORDS are no less robust than ordinary tough rubber sheathed flexible cord (IEC 60245-1:2003, Annex A, designation 53) or ordinary polyvinyl chloride sheathed flexible cord (IEC 60227-1:1993, Annex A, design 53)		N
	Only polyvinyl chloride insulated POWER SUPPLY CORD with appropriate temperature rating used for ME EQUIPMENT having external metal parts with a temperature > 75 °C touchable by the cord in NORMAL USE		N
8.11.3.3	NOMINAL cross-sectional area of conductors of POWER SUPPLY CORDS of ME EQUIPMENT is not less than in Table 17		N

IEC 60601-1			
Clause	Requirement + Test	Result - Remark	Verdict
8.11.3.4	APPLIANCE COUPLERS complying with IEC 60320-1 are considered to comply with 8.11.3.5 and 8.11.3.6..... :		N
8.11.3.5	Cord anchorage		N
	a) Conductors of POWER SUPPLY CORD provided with strain relief and insulation protected from abrasion at point of entry to ME EQUIPMENT or a MAINS CONNECTOR by a cord anchorage		N
	b) Cord anchorage of POWER SUPPLY CORD is an insulating material, or		N
	– metal, insulated from conductive ACCESSIBLE PARTS non-PROTECTIVELY EARTHED by a MEANS OF PROTECTION, or		N
	– metal provided with an insulating lining affixed to cord anchorage		N
	c) Cord anchorage prevents cord from being clamped by a screw bearing directly on cord insulation		N
	d) Screws to be operated when replacing POWER SUPPLY CORD do not serve to secure any components		N
	e) Conductors of POWER SUPPLY CORD arranged to prevent PROTECTIVE EARTH CONDUCTOR against strain as long as phase conductors are in contact with their terminals		N
	f) Cord anchorage prevents POWER SUPPLY CORD from being pushed into ME EQUIPMENT or MAINS CONNECTOR		N
	Conductors of POWER SUPPLY CORD supplied by MANUFACTURER disconnected from terminals or from MAINS CONNECTOR and cord subjected 25 times to a pull applied with no jerks, each time for 1 s, on sheath of the value in Table 18..... :		N
	Cord subjected to a torque in Table 18 for one minute immediately after pull tests		N
	Cord anchorage did not allow cord sheath to be longitudinally displaced by more than 2 mm or conductor ends to move over a distance of more than 1 mm from their connected position		N
	CREEPAGE and CLEARANCES not reduced below limits in 8.9		N
	It was not possible to push the cord into ME EQUIPMENT or MAINS CONNECTOR to an extent the cord or internal parts would be damaged		N
8.11.3.6	POWER SUPPLY CORDS protected against excessive bending at inlet opening of equipment		N
	Cord guard complied with test of IEC 60335-1:2001, Clause 25.14, or		N

IEC 60601-1			
Clause	Requirement + Test	Result - Remark	Verdict
	ME EQUIPMENT placed such that axis of cord guard projected at an angle of 45° with cord free from stress, and a mass equal 10 x D ² gram attached to the free end of cord (g)		N
	Cord guard of temperature-sensitive material tested at 23 °C ± 2 °C, and flat cords bent in the plane of least resistance		N
	Curvature of the cord radius, immediately after mass attached, was not less than 1.5 x D		N
8.11.4	MAINS TERMINAL DEVICES		N
8.11.4.1	PERMANENTLY INSTALLED and ME EQUIPMENT with non-DETACHABLE POWER SUPPLY CORD provided with MAINS TERMINAL DEVICES ensuring reliable connection		N
	Terminals alone are not used to keep conductors in position		N
	Terminals of components other than terminal blocks complying with requirements of this Clause and marked accordingly used as terminals intended for external conductors		N
	Screws and nuts clamping external conductors do not serve to secure any other component		N
8.11.4.2	Arrangement of MAINS TERMINAL DEVICES		N
	a) Terminals provided for connection of external cords or POWER SUPPLY CORDS together with PROTECTIVE EARTH TERMINAL grouped to provide convenient means of connection		N
	d) MAINS TERMINAL DEVICES not accessible without use of a TOOL		N
	e) A MEANS OF PROTECTION are not short circuited when one end of a flexible conductor with NOMINAL cross-sectional area is stripped 8 mm and a single free wire is bent in each possible direction		N
8.11.4.3	Internal wiring not subjected to stress and CREEPAGE and CLEARANCES not reduced after fastening and loosening a conductor of largest cross-sectional area 10 times		N
8.11.4.4	Terminals with clamping means for a rewirable flexible cord did not require special preparation of conductors and conductors were not damaged and did not slip out when clamping means tightened		N
8.11.4.5	Adequate space provided inside ME EQUIPMENT designed for FIXED wiring or a rewirable POWER SUPPLY CORD to allow for connection of conductors		N
	Correct connection and positioning of conductors before ACCESS COVER verified by an installation test		N
8.11.5	Mains fuses and OVER-CURRENT RELEASES		N

IEC 60601-1			
Clause	Requirement + Test	Result - Remark	Verdict
	A fuse or OVER-CURRENT RELEASE provided in each supply lead for CLASS I and CLASS II ME EQUIPMENT with a functional earth connection		N
	- in at least one supply lead for other single-phase CLASS II ME EQUIPMENT		N
	– neutral conductor not fused for PERMANENTLY INSTALLED ME EQUIPMENT		N
	– fuses or OVER-CURRENT RELEASES omitted due to provision of two MEANS OF PROTECTION between all parts within MAINS PART		N
	Protective devices have adequate breaking capacity to interrupt the max. fault current		N
	A fuse or OVER-CURRENT RELEASE not provided in a PROTECTIVE EARTH CONDUCTOR		N
	Justification for omission of fuses or OVER-CURRENT RELEASES documented		N
8.11.6	Internal wiring of the MAINS PART		N
	a) Cross-sectional area of internal wiring in a MAINS PART between MAINS TERMINAL DEVICE or APPLIANCE INLET and protective devices suitable		N
	b) Cross-sectional area of other wiring in MAINS PART and sizes of tracks on printed wiring circuits are sufficient		N
9	PROTECTION AGAINST MECHANICAL HAZARDS OF ME EQUIPMENT AND ME SYSTEMS		P
9.2	HAZARDS associated with moving parts		N
9.2.1	When ME EQUIPMENT with moving parts PROPERLY INSTALLED, used per ACCOMPANYING DOCUMENTS or under foreseeable misuse, RISKS associated with moving parts reduced to an acceptable level	No moving parts	N
	RISK from contact with moving parts reduced to an acceptable level using protective measures, (access, function, shape of parts, energy, speed of motion, and benefits to PATIENT considered)		N
	RESIDUAL RISK associated with moving parts considered acceptable when exposure was needed for ME EQUIPMENT to perform its intended function, and		N
	RISK CONTROLS implemented		N
	RISK MANAGEMENT FILE includes an assessment of RISKS associated with moving parts..... (ISO 14971 Cl. 4.2-4.4, 5, 6.2-6.5)		N
	All RISKS associated with moving parts have been reduced to an acceptable level		N
9.2.2	TRAPPING ZONE		N

IEC 60601-1			
Clause	Requirement + Test	Result - Remark	Verdict
9.2.2.1	ME EQUIPMENT with a TRAPPING ZONE complied with one or more of the following as feasible:	No TRAPPING zone	N
	– Gaps in Clause 9.2.2.2, or		N
	– Safe distances in Clause 9.2.2.3, or		N
	– GUARDS and other RISK CONTROL measures in 9.2.2.4, or		N
	– Continuous activation in Clause 9.2.2.5		N
	Control of relevant motion complied with 9.2.2.6 when implementation of above protective measures were inconsistent with INTENDED USE of ME EQUIPMENT or ME SYSTEM		N
9.2.2.2	A TRAPPING ZONE considered not to present a MECHANICAL HAZARD when gaps of TRAPPING ZONE complied with dimensions per Table 20		N
9.2.2.3	A TRAPPING ZONE considered not to present a MECHANICAL HAZARD when distances separating OPERATOR, PATIENT, and others from TRAPPING ZONES exceeded values in ISO 13857:2008		N
9.2.2.4	GUARDS and other RISK CONTROL measures		N
9.2.2.4.1	A TRAPPING ZONE do not to present a MECHANICAL HAZARD when GUARDS or other RISK CONTROL measures are of robust construction, not easy to bypass or render non-operational, and did not introduce additional unacceptable RISK		N
9.2.2.4.2	FIXED GUARDS held in place by systems that can only be dismantled with a TOOL		N
9.2.2.4.3	Movable GUARDS that can be opened without a TOOL remained attached when GUARD was open		N
	– they are associated with an interlock preventing relevant moving parts from starting to move while TRAPPING ZONE is accessible, and stops movement when the GUARD is opened,		N
	– absence or failure of one of their components prevents starting, and stops moving parts		N
	Movable GUARDS complied with any applicable tests		N
9.2.2.4.4	Other RISK CONTROL designed and incorporated into the control system stops movement and		N
	– SINGLE FAULT CONDITIONS have a second RISK CONTROL, or		N
	ME EQUIPMENT is SINGLE FAULT SAFE		N
9.2.2.5	Continuous activation		N
	Continuous activation used as a RISK CONTROL, complies with the following		N
	a) movement was in OPERATOR'S field of view		N

IEC 60601-1			
Clause	Requirement + Test	Result - Remark	Verdict
	b) movement of ME EQUIPMENT or its parts was possible only by continuous activation of control by OPERATOR		N
	c) a second RISK CONTROL provided for SINGLE FAULT CONDITION of continuous activation system, or		N
	- the continuous activation system is SINGLE FAULT SAFE		N
9.2.2.6	Speed of movement(s) positioning parts of ME EQUIPMENT or PATIENT limited to allow OPERATOR control of the movement		N
	Over travel of such movement occurring after operation of a control to stop movement, did not result in an unacceptable RISK		N
9.2.3	Other MECHANICAL HAZARDS associated with moving parts		N
9.2.3.1	Controls positioned, recessed, or protected by other means so that they cannot be accidentally actuated	No such mechanical hazards	N
	- unless for the intended PATIENT, the USABILITY ENGINEERING PROCESS concludes otherwise (e.g. PATIENT with special needs), or		N
	- activation does not result in an unacceptable RISK		N
9.2.3.2	Over travel past range limits of the ME EQUIPMENT prevented..... :		N
	Over travel means provided with mechanical strength to withstand loading in NORMAL CONDITION & reasonably foreseeable misuse :		N
9.2.4	Emergency stopping devices		N
	Where necessary to have one or more emergency stopping device(s), emergency stopping device complied with all the following, except for actuating switch capable of interrupting all power :	No emergency stopping devices	N
	a) Emergency stopping device reduced RISK to an acceptable level		N
	RISK MANAGEMENT FILE indicates the use of an emergency stopping device reduces the RISK to an acceptable level : (ISO 14971 Cl. 4.2-4.4, 5, 6.2-6.6)		N
	b) Proximity and response of OPERATOR to actuate emergency stopping device could be relied upon to prevent HARM		N
	c) Emergency stopping device actuator was readily accessible to OPERATOR		N
	d) Emergency stopping device(s) are not part of normal operation of ME EQUIPMENT		N

IEC 60601-1			
Clause	Requirement + Test	Result - Remark	Verdict
	e) Emergency switching operation or stopping means neither introduced further HAZARD nor interfered with operation necessary to remove original MECHANICAL HAZARD		N
	f) Emergency stopping device was able to break full load of relevant circuit, including possible stalled motor currents and the like		N
	g) Means for stopping of movements operate as a result of one single action		N
	h) Emergency stopping device provided with an actuator in red and easily distinguishable and identifiable from other controls		N
	i) An actuator interrupting/opening mechanical movements marked on or immediately adjacent to face of actuator with symbol 18 of Table D.1 or "STOP"		N
	j) Emergency stopping device, once actuated, maintained ME EQUIPMENT in disabled condition until a deliberate action, different from that used to actuate it, was performed		N
	k) Emergency stopping device is suitable for its application		N
9.2.5	Means provided to permit quick and safe release of PATIENT in event of breakdown of ME EQUIPMENT or failure of power supply, activation of a RISK CONTROL measure, or emergency stopping..... :	No release of patient	N
	– and uncontrolled or unintended movement of ME EQUIPMENT that could result in an unacceptable RISK prevented		N
	– Situations where PATIENT is subjected to unacceptable RISKS due to proximity of moving parts, removal of normal exit routes, or other HAZARDS prevented		N
	– Measures provided to reduce RISK to an acceptable level when after removal of counterbalanced parts, other parts of ME EQUIPMENT can move in a hazardous way		N
	RISK MANAGEMENT FILE includes an assessment of RISKS to the PATIENT related to breakdown of the ME EQUIPMENT..... : (ISO 14971 Cl. 4.2-4.4, 5, 6.2-6.5)		N
9.3	Rough surfaces, sharp corners and edges of ME EQUIPMENT that could result in injury or damage avoided or covered	Surfaces, corners and edges are rounded	P
9.4	Instability HAZARDS		N
9.4.1	ME EQUIPMENT and its parts, other than FIXED, for placement on a surface did not overbalance (tip over) or move unexpectedly in NORMAL USE		N
9.4.2	Instability – overbalance		N

IEC 60601-1			
Clause	Requirement + Test	Result - Remark	Verdict
9.4.2.1	ME EQUIPMENT or its parts did not overbalance when prepared per ACCOMPANYING DOCUMENTS, or when tested		N
9.4.2.2	Instability excluding transport		N
	ME EQUIPMENT or its did not overbalance when placed in different positions of NORMAL USE,..... :		N
	A warning provided when overbalance occurred during 10° inclined plane test		N
9.4.2.3	Instability from horizontal and vertical forces		N
	a) ME EQUIPMENT or its parts with a mass of 25kg or more, intended to be used on the floor, didn't overbalance due to pushing, leaning against it		N
	Surfaces of ME EQUIPMENT or its parts where a RISK of overbalancing exists from pushing, etc., permanently marked with a warning of the RISK		N
	ME EQUIPMENT did not overbalance when tested according to Cl. 9.4.2.3 a)		N
	b) ME EQUIPMENT, for use on the floor or on a table, did not overbalance due to sitting or stepping		N
	ME EQUIPMENT or its parts, for use on the floor or on a table, where RISK of overbalancing exists, permanently marked with the RISK warning		N
	ME EQUIPMENT did not overbalance when tested according to Cl. 9.4.2.3b)		N
9.4.2.4	Castors and wheels		N
9.4.2.4.1	Means used for transportation of MOBILE ME EQUIPMENT did not result in an unacceptable RISK when MOBILE ME EQUIPMENT moved or parked in NORMAL USE	No castors and wheels	N
9.4.2.4.2	Force required to move MOBILE ME EQUIPMENT did not exceed 200 N		N
9.4.2.4.3	MOBILE ME EQUIPMENT exceeding 45 kg able to pass over threshold		N
9.4.3	Instability from unwanted lateral movement (including sliding)		N
9.4.3.1	a) Brakes of power-driven MOBILE ME EQUIPMENT normally activated and could only be released by continuous actuation of a control	No mobile me equipment	N
	b) MOBILE ME EQUIPMENT provided with locking means to prevent unwanted movements		N
	c) No unwanted lateral movement resulted when MOBILE ME EQUIPMENT placed in its transport position when test per 9.4.3.1		N
9.4.3.2	Instability excluding transport		N
	a) MOBILE ME EQUIPMENT provided with wheel locks or braking system compliant with 5° tilt test		N

IEC 60601-1			
Clause	Requirement + Test	Result - Remark	Verdict
	b) MOBILE ME EQUIPMENT provided with wheel locks or braking system compliant with lateral stability test		N
9.4.4	Grips and other handling devices		N
	a) ME EQUIPMENT with a mass of over 20 kg requiring lifting in NORMAL USE or transport provided with suitable handling means, or ACCOMPANYING DOCUMENTS specify safe lifting method	No grips and other handling devices	N
	Handles, suitably placed to enable ME EQUIPMENT or its part to be carried by two or more persons and by examination of EQUIPMENT, its part, or ACCOMPANYING DOCUMENTS		N
	b) PORTABLE ME EQUIPMENT with a mass > 20 kg provided with one or more carrying-handles suitably placed to enable carrying by two or more persons as confirmed by actual carrying		N
	c) Carrying handles and grips and their means of attachment withstood loading test		N
9.5	Expelled parts HAZARD		N
9.5.1	Suitability of means of protecting against expelled parts determined by assessment and examination of RISK MANAGEMENT FILE..... : (ISO 14971 Cl. 4.3, 4.4, 5, 6.2-6.5)	No expelled parts	N
	All identified RISKS associated with expelled parts mitigated to an acceptable level		N
9.5.2	Cathode Ray tube(s) complied with IEC 60065:2001, Clause 18, or IEC 61965		N
9.6	Acoustic energy (including infra- and ultrasound) and vibration		P
9.6.1	Human exposure to acoustic energy and vibration from ME EQUIPMENT doesn't result in unacceptable RISK and		P
	If necessary, confirmed in RISK MANAGEMENT FILE including audibility of auditory alarm signals, and PATIENT sensitivity	Test are conducted	N
	If necessary, confirmed in RISK MANAGEMENT FILE including audibility of auditory alarm signals, PATIENT sensitivity, and (ISO 14971 Cl. 4.2-44, 5, 6.2-6.5)		N
	All identified RISKS mitigated to an acceptable level		N
9.6.2	Acoustic energy		P
9.6.2.1	PATIENT, OPERATOR, and other persons are not exposed to acoustic energy from ME EQUIPMENT in NORMAL USE		P
	- 80 dBA for a cumulative exposure of 24 h over a 24 h period (dBA)		—
	- 83 dBA (when halving the cumulative exposure time) (dBA).....	<50	—

IEC 60601-1			
Clause	Requirement + Test	Result - Remark	Verdict
	– 140 dBC (peak) sound pressure level for impulsive or impact acoustic energy (dB)..... :		—
9.6.2.2	RISK MANAGEMENT FILE examined..... : (ISO 14971 Cl. 4.2-4.4, 5, 6.2-6.5)	No infrasound or ultrasound energy	N
9.6.3	Hand-transmitted vibration		N
	Means provided to protect PATIENT and OPERATOR when hand-transmitted frequency-weighted r.m.s. acceleration generated in NORMAL USE exceeds specified values	No hand-transmitted vibration	N
	– 2.5 m/s ² for a cumulative time of 8 h during a 24 h period (m/s ²)		N
	– Accelerations for different times, inversely proportional to square root of time (m/s ²)..... :		N
9.7	Pressure vessels and parts subject to pneumatic and hydraulic pressure		N
9.7.2	Pneumatic and hydraulic parts of ME EQUIPMENT or ACCESSORIES met requirements based on examination of RISK MANAGEMENT FILE : (ISO 14971 Cl. 4.3-4.4, 5, 6.2-6.5)	No pneumatic and hydraulic parts	N
	– No unacceptable RISK resulted from loss of pressure or loss of vacuum		N
	– No unacceptable RISK resulted from a fluid jet caused by leakage or a component failure		N
	– Elements of ME EQUIPMENT or an ACCESSORY, especially pipes and hoses leading to an unacceptable RISK protected against harmful external effects		N
	– Reservoirs and similar vessels leading to an unacceptable RISK are automatically depressurized when ME EQUIPMENT is isolated from its power supply		N
	Means provided for isolation, or local depressurizing reservoirs and similar vessels, and pressure indication when above not possible		N
	– All elements remaining under pressure after isolation of ME EQUIPMENT or an ACCESSORY from its power supply resulting in an unacceptable RISK provided with clearly identified exhaust devices, and a warning to depressurize these elements before setting or maintenance activity		N
9.7.3	Maximum pressure a part of ME EQUIPMENT can be subjected to in NORMAL and SINGLE FAULT CONDITIONS considered to be highest of following:		N
	a) RATED maximum supply pressure from an external source		N
	b) Pressure setting of a pressure-relief device provided as part of assembly		N

IEC 60601-1			
Clause	Requirement + Test	Result - Remark	Verdict
	c) Max pressure that can develop by a source of pressure that is part of assembly, unless pressure limited by a pressure-relief device		N
9.7.4	Max pressure in NORMAL and SINGLE FAULT CONDITIONS did not exceed MAXIMUM PERMISSIBLE WORKING PRESSURE for EQUIPMENT part, except as allowed in 9.7.7, confirmed by inspection of THE MANUFACTURER'S data for the component, ME EQUIPMENT, and by functional tests..... :		N
9.7.5	A pressure vessel withstood a HYDRAULIC TEST PRESSURE when pressure was more than 50 kPa, and product of pressure and volume was more than 200 kPal		N
9.7.6	Pressure-control device regulating pressure in ME EQUIPMENT with pressure-relief device completed 100,000 cycles of operation under RATED load and prevented pressure from exceeding 90 % of setting of pressure-relief device in different conditions of NORMAL USE		N
9.7.7	Pressure-relief device(s) used where MAXIMUM PERMISSIBLE WORKING PRESSURE could otherwise be exceeded met the following, as confirmed by MANUFACTURER'S data, ME EQUIPMENT, RISK MANAGEMENT FILE, and functional tests..... :		N
	a) Connected as close as possible to pressure vessel or parts of system it is to protect		N
	b) Installed to be readily accessible for inspection, maintenance, and repair		N
	c) Could be adjusted or rendered inoperative without a TOOL		N
	d) With discharge opening located and directed as to not to release material towards any person		N
	e) With discharge opening located and directed as to not to deposit material on parts that could result in an unacceptable RISK		N
	f) Adequate discharge capacity provided to ensure that pressure will not exceed MAXIMUM PERMISSIBLE WORKING PRESSURE of system it is connected to by more than 10 % when failure occurs in control of supply pressure		N
	g) No shut-off valve provided between a pressure-relief device and parts it is to protect		N
	h) Min number of cycles of operation 100 000, except for one-time use devices (bursting disks)		N
	RISK MANAGEMENT FILE includes an assessment of the risks associated with the discharge opening of the pressure relief device		N
	(ISO 14971 Cl. 4.3, 4.4, 5, 6.2-6.5)		N
9.8	HAZARDS associated with support systems		N

IEC 60601-1			
Clause	Requirement + Test	Result - Remark	Verdict
9.8.1	ME EQUIPMENT parts designed to support loads or provide actuating forces when a mechanical fault could constitute an unacceptable RISK	No support systems	N
	– Construction of support, suspension, or actuation system complied with Table 21 and TOTAL LOAD		N
	– Means of attachment of ACCESSORIES prevent possibility of incorrect attachment that could result in an unacceptable RISK		N
	– RISK ANALYSIS of support systems included MECHANICAL HAZARDS from static, dynamic, vibration, foundation and other movements, impact and pressure loading, temperature, environmental, manufacture and service conditions		N
	(ISO 14971 Cl. 4.2-4.4, 5, 6.2-6.5)		
	– RISK ANALYSIS included effects of failures such as excessive deflection, plastic deformation, ductile/brittle fracture, fatigue fracture, instability (buckling), stress-assisted corrosion cracking, wear, material creep and deterioration, and residual stresses from manufacturing PROCESSES		N
	– Instructions on attachment of structures to a floor, wall, ceiling, included in ACCOMPANYING DOCUMENTS making adequate allowances for quality of materials used to make the connection and list the required materials		N
	Additional instructions provided on checking adequacy of surface of structure parts will be attached to		N
9.8.2	Support systems maintain structural integrity during EXPECTED SERVICE LIFE, and TENSILE SAFETY FACTORS are not less than in Table 21, except when an alternative method used to demonstrate structural integrity throughout EXPECTED SERVICE LIFE, or for a foot rest		N
	Compliance with 9.8.1 and 9.8.2 confirmed by examination of ME EQUIPMENT, RISK MANAGEMENT FILE, specifications and material processing.....		N
	RISK MANAGEMENT FILE includes an assessment of the structural integrity of support system.....		N
	(ISO 14971 Cl. 4.3-4.4, 5, 6.2-6.5)		
	All identified RISKS are mitigated to an acceptable level		N
	When test were conducted, testing consisted of application of a test load to support assembly equal to TOTAL LOAD times required TENSILE SAFETY FACTOR while support assembly under test was in equilibrium after 1 min, or not resulted in an unacceptable RISK		N

IEC 60601-1			
Clause	Requirement + Test	Result - Remark	Verdict
	Where the equipment is not at equilibrium after 1 min, the RISK MANAGEMENT FILE includes an assessment of the test results : (ISO 14971 Cl. 4.3-4.4, 5, 6.2-6.5)		N
9.8.3	Strength of PATIENT or OPERATOR support or suspension systems		N
9.8.3.1	ME EQUIPMENT parts supporting or immobilizing PATIENTS presents no unacceptable RISK of physical injuries and accidental loosening of secured joints :		N
	RISK MANAGEMENT FILE includes assessment of the RISKS associated with physical injuries and accidental loosening of fixings..... : (ISO 14971 Cl. 4.2-4.4, 5, 6.2-6.5)		N
	SAFE WORKING LOAD of ME EQUIPMENT or its parts supporting or suspending PATIENTS or OPERATORS is sum of mass of PATIENTS or mass of OPERATORS plus mass of ACCESSORIES supported by ME EQUIPMENT or its parts		N
	Supporting and suspending parts for adult human PATIENTS or OPERATORS designed for a PATIENT or OPERATOR with a min mass of 135 kg and ACCESSORIES with a min mass of 15 kg, unless stated by MANUFACTURER		N
	Maximum mass of PATIENT included in SAFE WORKING LOAD of ME EQUIPMENT or its parts supporting or suspending PATIENTS adapted when MANUFACTURER specified applications		N
	Max allowable PATIENT mass < 135 kg marked on ME EQUIPMENT and stated in ACCOMPANYING DOCUMENTS		N
	Max allowable PATIENT mass over 135 kg stated in ACCOMPANYING DOCUMENTS		N
	Examination of markings, ACCOMPANYING DOCUMENTS, and RISK MANAGEMENT FILE confirmed compliance :		N
9.8.3.2	a) Entire mass of PATIENT or OPERATOR distributed over an area of 0.1 m ² on a foot rest temporarily supporting a standing PATIENT or OPERATOR..... :		N
	Compliance confirmed by examination of ME EQUIPMENT specifications of materials and their processing, and tests..... :		N
	b) Deflection of a support surface from PATIENT or OPERATOR loading on an area of support/ suspension where a PATIENT or OPERATOR can sit did not result in an unacceptable RISK		N
	Compliance confirmed by examination of ME EQUIPMENT, specifications of materials and their processing, and by a test..... :		N

IEC 60601-1			
Clause	Requirement + Test	Result - Remark	Verdict
9.8.3.3	Dynamic forces that can be exerted on equipment parts supporting or suspending a PATIENT or OPERATOR in NORMAL USE maintained BASIC SAFETY and ESSENTIAL PERFORMANCE confirmed test		N
9.8.4	Systems with MECHANICAL PROTECTIVE DEVICES		N
9.8.4.1	a) A MECHANICAL PROTECTIVE DEVICE provided for the support system		N
	b) MECHANICAL PROTECTIVE complies with the requirements as follows:		N
	– Designed based on TOTAL LOAD		N
	– Has TENSILE SAFETY FACTORS for all parts not less than Table 21, row 7		N
	– Activated before travel produced an unacceptable RISK		N
	– Takes into account Clauses 9.2.5 and 9.8.4.3		N
	Compliance confirmed by examination of ME EQUIPMENT over travel calculations and evaluation plus functional tests		N
9.8.4.2	Activation of MECHANICAL PROTECTIVE DEVICE is made obvious to OPERATOR when ME EQUIPMENT can still be used after failure of suspension or actuation means and activation of a MECHANICAL PROTECTIVE DEVICE		N
	MECHANICAL PROTECTIVE DEVICE requires use of a TOOL to be reset or replaced		N
9.8.4.3	MECHANICAL PROTECTIVE DEVICE intended to function once		N
	–use of ME EQUIPMENT not possible until replacement of MECHANICAL PROTECTIVE DEVICE . :		N
	– ACCOMPANYING DOCUMENTS provided with required information on replacement by service personal		N
	– ME EQUIPMENT permanently marked with safety sign 2 of Table D.		N
	– Marking is adjacent to MECHANICAL PROTECTIVE DEVICE		N
	– Compliance confirmed by examination and following test..... :		N
	A chain, cable, band, spring, belt, jack screw nut, pneumatic or hydraulic hose, structural part or the like, employed to support a load, defeated by a convenient means causing maximum normal load to fall from most adverse position permitted by construction of ME EQUIPMENT		N
	Load included SAFE WORKING LOAD in 9.8.3.1 when system was capable of supporting a PATIENT or OPERATOR		N

IEC 60601-1			
Clause	Requirement + Test	Result - Remark	Verdict
	No evidence of damage to MECHANICAL PROTECTIVE DEVICE affecting its ability to perform its intended function		N
9.8.5	Systems without MECHANICAL PROTECTIVE DEVICES		N
	Support Systems does not require MECHANICAL PROTECTIVE DEVICES..... :		N
	RISK MANAGEMENT FILE includes an assessment of RISKS associated with wear on the support system : (ISO 14971 Cl. 4.3,4.4,5,6.2-6.5)		N

10	PROTECTION AGAINST UNWANTED AND EXCESSIVE RADIATION HAZARDS		N
10.1	X-Radiation		N
10.1.1	The air kerma did not exceed 5 µGy/hat 5 cm from surface of ME EQUIPMENT..... :	No X-Radiation	N
	Annual exposure reduced taking into account the irradiated body part, national regulations, and/or international recommendations for ME EQUIPMENT that has permanent proximity to a PATIENT as part of the INTENDED USE		N
10.1.2	RISK from unintended X-radiation from ME EQUIPMENT producing X-radiation for diagnostic and therapeutic purposes addressed application of applicable particular and collateral standards, or :		N
	RISK MANAGEMENT PROCESS as indicated in RISK MANAGEMENT FILE..... : (ISO 14971 Cl. 4.2-4.4, 5, 6.2-6.5)		N
10.2	RISK associated with alpha, beta, gamma, neutron, and other particle radiation, addressed in RISK MANAGEMENT PROCESS as shown in RISK MANAGEMENT FILE : (ISO 14971 Cl. 4.2-4.4, 5, 6.2-6.5)		N
10.3	The power density of unintended microwave radiation at frequencies between 1 GHz and 100 GHz does not exceed 10 W/m ²		N
	Microwave radiation is propagated intentionally		N
10.4	Relevant requirements of IEC 60825-1:2007 applied to lasers, laser light barriers or similar with a wavelength range of 180nm to 1 mm.		N
10.5	RISK associated with visible electromagnetic radiation other than emitted by lasers and LEDs, when applicable, addressed in RISK MANAGEMENT PROCESS as indicated in RISK MANAGEMENT FILE... : (ISO 14971 Cl. 4.2-4.4, 5, 6.2-6.5)		N
10.6	RISK associated with infrared radiation other than emitted by lasers and LEDs addressed in RISK MANAGEMENT PROCESS as indicated in RISK MANAGEMENT FILE : (ISO 14971 Cl. 4.2-4.4, 5, 6.2-6.5)		N

IEC 60601-1			
Clause	Requirement + Test	Result - Remark	Verdict
10.7	RISK associated with ultraviolet radiation other than emitted by lasers and LEDS addressed in RISK MANAGEMENT PROCESS as indicated in RISK MANAGEMENT FILE : (ISO 14971 Cl. 4.2-4.4, 5, 6.2-6.5)		N
11	PROTECTION AGAINST EXCESSIVE TEMPERATURES AND OTHER HAZARDS		P
11.1	Excessive temperatures in ME EQUIPMENT		P
11.1.1	Temperatures on ME EQUIPMENT parts did not exceed values in Tables 22 and : Surfaces of test corner did not exceed 90 °C	See appended Table 11.1.1	P
	THERMAL CUT-OUTS did not operate in NORMAL CONDITION	No thermal cut-outs	N
	RISK MANAGEMENT FILE includes an assessment of the duration of contact for all APPLIED PARTS and ACCESSIBLE PARTS : (ISO 14971 Cl. 4.2-4.4, 5, 6.2-6.5)	RMF Reference to specific RISKS: YMDK-RD-C101H1-0005/A0, YMDK-RD-C101H1-0002/A0, and YMDK-RD-C101H1-0007/A0 (ISO 14971 Cl. 4.2-4.4, 5, 6.2-6.5)	P
11.1.2	Temperature of APPLIED PARTS		P
11.1.2.1	APPLIED PARTS (hot or cold intended to supply heat to a PATIENT comply : Clinical effects determined and documented in the RISK MANAGEMENT FILE (ISO 14971 Cl. 4.2-4.4, 5, 6.2-6.5)	Not intended to supply heat to a patient	N
	Temperature (hot or cold) of APPLIED PARTS intended to supply heat to a PATIENT disclosed in the instructions for use		N
11.1.2.2	APPLIED PARTS not intended to supply heat to a PATIENT complies with the limits of Table 24 in NORMAL CONDITION and SINGLE FAULT CONDITION.. : APPLIED PARTS surface temperature exceeds 41°C disclosed in the instruction manual:	< 41°C	N
	Maximum Temperature..... :		—
	Conditions for safe contact, e.g. duration or condition of the PATIENT :		—
	Clinical effects with respect to characteristics taken or surface pressure documented in the RISK MANAGEMENT FILE (ISO 14971 Cl. 4.2-4.4, 5, 6.2-6.5)	No clinical effects	N
	APPLIED PARTS surface temperature of equal to or less than 41°C		P

IEC 60601-1			
Clause	Requirement + Test	Result - Remark	Verdict
	Analysis documented in the RISK MANAGEMENT FILE show that APPLIED PART temperatures are not affected by operation of the ME EQUIPMENT including SINGLE FAULT CONDITIONS. Measurement of APPLIED PART temperature according to 11.1.3 is not conducted	Test is conducted according to clause 11.1.3	N
	Surfaces of APPLIED PARTS that are cooled below ambient temperatures evaluated in the RISK MANAGEMENT PROCESS		N
11.1.3	Measurements not made when engineering judgment and rationale by MANUFACTURER indicated temperature limits could not exceed, as documented in RISK MANAGEMENT FILE	Measurements conducted	N
	Test corner not used where engineering judgment and rationale by MANUFACTURER indicated test corner will not impact measurements, as documented in RISK MANAGEMENT FILE	Test corner used	N
	Probability of occurrence and duration of contact for parts likely to be touched and for APPLIED PARTS documented in RISK MANAGEMENT FILE	RMF Reference to specific RISKS: YMDK-RD-C101H1-0005/A0, YMDK-RD-C101H1-0002/A0, and YMDK-RD-C101H1-0007/A01 (ISO 14971 Cl. 4.2-4.4, 5, 6.2-6.5)	P
	e) Where thermal regulatory devices make this method inappropriate, alternative methods for measurement are justified in the RISK MANAGEMENT FILE	No alternative methods	N
11.1.4	GUARDS preventing contact with hot or cold accessible surfaces removable only with a TOOL	No such guards	N
11.2	Fire prevention		P
11.2.1	ENCLOSURE has strength and rigidity necessary to prevent a fire and met mechanical strength tests for ENCLOSURES in 15.3		P
11.2.2	Me equipment and me systems used in conjunction with OXYGEN RICH ENVIRONMENTS		N
11.2.2.1	RISK of fire in an OXYGEN RICH ENVIRONMENT reduced by means limiting spread of	Not intended to used in conjunction with oxygen rich environments	N
	a) No sources of ignition discovered in an OXYGEN RICH ENVIRONMENT under any of the following conditions		N
	1) when temperature of material raised to its ignition temperature		N

IEC 60601-1			
Clause	Requirement + Test	Result - Remark	Verdict
	2) when temperatures affected solder or solder joints causing loosening, short circuiting, or other failures causing sparking or increasing material temperature to its ignition temperature		N
	3) when parts affecting safety cracked or changed outer shape exposing temperatures higher than 300°C or sparks due to overheating		N
	4) when temperatures of parts or components exceeded 300°C, atmosphere was 100 % oxygen, contact material solder, and fuel cotton		N
	5) when sparks provided adequate energy for ignition by exceeding limits of Figs 35 to 37 (inclusive), atmosphere was 100 % oxygen, contact material solder, and fuel cotton		N
	Deviations from worst case limits in 4) and 5) above based on lower oxygen concentrations or less flammable fuels justified and documented in RISK MANAGEMENT FILE..... : (ISO 14971 Cl. 4.2-4.4, 5, 6.2-6.5)		N
	Alternative test in this clause did not identify existence of ignition sources at highest voltage or current, respectively..... :		N
	A safe upper limit determined by dividing upper limit of voltage or current, respectively, with safety margin factor of three..... :		N
	b) RESIDUAL RISK of fire in an OXYGEN RICH ENVIRONMENT as determined by application of RISK MANAGEMENT PROCESS is based on following configurations, or in combination : (ISO 14971 Cl. 4.2-4.4, 5, 6.2-6.5)		N
	1) Electrical components in an OXYGEN RICH ENVIRONMENT provided with power supplies having limited energy levels lower than those considered sufficient for ignition in 11.2.2.1 a) as determined by examination, measurement or calculation of power, energy, and temperatures in NORMAL and SINGLE FAULT CONDITIONS identified in 11.2.3 :		N
	2) Max oxygen concentration measured until it did not exceed 25 % in ventilated compartments with parts that can be a source of ignition only in SINGLE FAULT CONDITION and can be penetrated by oxygen due to an undetected leak (%)...... :		N
	3) A compartment with parts or components that can be a source of ignition only under SINGLE FAULT CONDITION separated from another compartment containing an OXYGEN RICH ENVIRONMENT by sealing all joints and holes for cables, shafts, or other purposes		N

IEC 60601-1			
Clause	Requirement + Test	Result - Remark	Verdict
	Effect of possible leaks and failures under SINGLE FAULT CONDITION that could cause ignition evaluated using a RISK ASSESSMENT to determine maintenance intervals by examination of documentation and RISK MANAGEMENT FILE		N
	4) Fire initiated in ENCLOSURE of electrical components in a compartment with OXYGEN RICH ENVIRONMENT that can become a source of ignition only under SINGLE FAULT CONDITIONS self-extinguished rapidly and no hazardous amount of toxic gases reached PATIENT as determined by analysis of gases		N
11.2.2.2	RISK of ignition did not occur and oxygen concentration did not exceed 25% in immediate surroundings due to location of external exhaust outlets of an OXYGEN RICH ENVIRONMENT		N
11.2.2.3	Electrical connections within a compartment containing an OXYGEN RICH ENVIRONMENT under NORMAL USE did not produce sparks		N
	– Screw-attachments protected against loosening during use by varnishing, use of spring washers, or adequate torques		N
	– Soldered, crimped, and pin-and-socket connections of cables exiting ENCLOSURE include additional mechanical securing means		N
11.2.3	SINGLE FAULT CONDITIONS related to OXYGEN RICH ENVIRONMENTS ME EQUIPMENT and ME SYSTEMS considered		N
	– Failure of a ventilation system constructed in accordance with 11.2.2.1 b) 2)	Not intended to used in conjunction with oxygen rich environments	N
	– Failure of a barrier constructed in accordance with 11.2.2.1 b) 3)		N
	– Failure of a component creating a source of ignition (as defined in 11.2.2.1 a)		N
	– Failure of solid insulation or creepage and clearances providing equivalent of at least one MEANS OF PATIENT PROTECTION but less than two MEANS OF PATIENT PROTECTION that could create a source of ignition defined in 11.2.2.1 a).....		N
	– Failure of a pneumatic component resulting in leakage of oxygen-enriched gas.....		N
11.3	Constructional requirements for fire ENCLOSURES of ME EQUIPMENT		N
	ME EQUIPMENT met this clause for alternate means of compliance with selected HAZARDOUS SITUATIONS and fault conditions in 13.1.2	Fault conditions is simulated	N
	Constructional requirements were met, or		N
	- constructional requirements specifically analysed in RISK MANAGEMENT FILE		N
	(ISO 14971 Cl. 4.2-4.4, 5, 6.2-6.5)		

IEC 60601-1			
Clause	Requirement + Test	Result - Remark	Verdict
	Justification, when requirement not met..... :		N
	a) Flammability classification of insulated wire within fire ENCLOSURE is FV-1, or better, based on IEC 60695 series as determined by examination of data on materials :		N
	Flammability classification of connectors, printed circuit boards, and insulating material on which components are mounted is FV-2, or better, based on IEC 60695-11-10 as decided by examination of materials data :		N
	If no FV Certification, FV tests based on IEC 60695-11-10 conducted on 3 samples of complete parts (or sections of it), including area with min. thickness, ventilation openings		N
	b) Fire ENCLOSURE met following:		N
	1) No openings at bottom or, as specified in Fig 39, constructed with baffles as in Fig 38, or made of perforated metal as in Table 25, or a metal screen with a mesh $\leq 2 \times 2$ mm centre to centre and wire diameter of at least 0.45 mm		N
	2) No openings on the sides within the area included within the inclined line C in Fig 39		N
	3) ENCLOSURE, baffles, and flame barriers have adequate rigidity and are made of appropriate metal or of non-metallic materials..... :		N
11.4	ME EQUIPMENT and ME SYSTEMS intended for use with flammable anaesthetics		N
	ME EQUIPMENT, ME SYSTEMS and parts described in ACCOMPANYING DOCUMENTS for use with flammable with Annex G	Not intended for use with flammable anaesthetics	N
11.5	ME EQUIPMENT and ME SYSTEMS intended for use in conjunction with flammable agents		N
	MANUFACTURER'S RISK MANAGEMENT PROCESS addresses possibility of fire and associated mitigations as confirmed by examination of RISK MANAGEMENT FILE : (ISO 14971 Cl. 4.2-4.4, 5, 6.2-6.5)	Not intended for use in conjunction with flammable agents	N
11.6	Overflow, spillage, leakage, ingress of water or particulate matter, cleaning, disinfection, sterilization and compatibility with substances used with the ME EQUIPMENT		P
11.6.1	Sufficient degree of protection provided against overflow, spillage, leakage, ingress of water or particulate matter, cleaning, disinfection and sterilization, and compatibility with substances used with ME EQUIPMENT :	See Appended Table 11.6.1	P
11.6.2	Overflow in ME EQUIPMENT		N
	ME EQUIPMENT incorporates a reservoir or liquid storage that did not wet any MEANS OF PROTECTION, nor result in the loss of BASIC SAFETY or ESSENTIAL PERFORMANCE :	No reservoir or liquid storage	N

IEC 60601-1			
Clause	Requirement + Test	Result - Remark	Verdict
	Maximum fill level is indicated by marking on the ME EQUIPMENT and a warning or safety notice is given, no HAZARDOUS SITUATION (as specified in 13.1) or unacceptable RISK due to overflow developed when the reservoir or liquid storage chamber is filled to its maximum capacity and the TRANSPORTABLE ME EQUIPMENT is tilted through an angle of 10°, or for MOBILE ME EQUIPMENT exceeding 45 kg, is moved over a threshold as described in 9.4.2.4.3.		N
	No warning or safety notice provided regarding the maximum fill level, no HAZARDOUS SITUATION (as specified in 13.1) or unacceptable RISK due to overflow developed when the reservoir or liquid storage chamber was filled to 15 % above the maximum capacity and the TRANSPORTABLE ME EQUIPMENT was tilted through an angle of 10°, or in MOBILE ME EQUIPMENT exceeding 45 kg, was moved over a threshold as described in 9.4.2.4.3.		N
11.6.3	Spillage on ME EQUIPMENT and ME SYSTEM		N
	ME EQUIPMENT and ME SYSTEMS handling liquids constructed that spillage does not wet parts as determined by review of the RISK MANAGEMENT FILE and test : (ISO 14971 Cl. 4.2-4.4, 5, 6.2-6.5)	Not intended for handling liquids	N
	RISK ANALYSIS identifies the type of liquid, volume, duration and location of the spill :		N
11.6.5	Ingress of water or particulate matter into ME EQUIPMENT and ME SYSTEMS		P
	ME EQUIPMENT with IP Code placed in least favourable position of NORMAL USE and subjected to tests of IEC 60529 (IP Code)..... :	See Appended Table 11.6.1	P
	ME EQUIPMENT met dielectric strength and LEAKAGE CURRENT tests and there were no bridging of insulation or electrical components that could result in the loss of BASIC SAFETY or ESSENTIAL PERFORMANCE in NORMAL CONDITION or in combination with a SINGLE FAULT CONDITION :	See appended Tables 8.7 8.8.3	P
11.6.6	Cleaning and disinfection of ME EQUIPMENT and ME SYSTEMS		P
	ME EQUIPMENT/ME SYSTEM and their parts and ACCESSORIES cleaned or disinfected using methods specified in instructions for use :	See Appended Tables 11.6.1, 8.7, and 8.8.3	P
	Effects of multiple cleanings/disinfections during EXPECTED SERVICE LIFE of EQUIPMENT evaluated by MANUFACTURER..... :	RMF Reference to specific RISKS: YMDK-RD-C101H1-0005/A0, YMDK-RD-C101H1-0002/A0, and YMDK-RD-C101H1-0007/A01	P
11.6.7	Sterilization of ME EQUIPMENT and ME SYSTEMS		N
	ME EQUIPMENT, ME SYSTEMS and their parts or ACCESSORIES intended to be sterilized assessed and documented and compliant with tests :	No sterilization	N

IEC 60601-1			
Clause	Requirement + Test	Result - Remark	Verdict
	RISK MANAGEMENT FILE includes an assessment of the RISKS associated with any deterioration following sterilization.....: (ISO 14971 Cl. 4.2-4.4, 5, 6.2-6.5)		N
11.6.8	RISKS associated with compatibility of substances used with ME EQUIPMENT addressed in RISK MANAGEMENT PROCESS (ISO 14971 Cl. 4.2-4.4, 5, 6.2-6.5)	No such substances	N
11.7	ME EQUIPMENT, ME SYSTEM, and ACCESSORIES coming into direct or indirect contact with biological tissues, cells, or body fluids assessed and documented	Evaluated by manufacturer	N
11.8	Interruption and restoration of power supply did not result in a loss of BASIC SAFETY or ESSENTIAL PERFORMANCE		P

12	ACCURACY OF CONTROLS AND INSTRUMENTS AND PROTECTION AGAINST HAZARDOUS OUTPUTS		N
12.1	RISKS associated with accuracy of controls and instruments stated: (ISO 14971 Cl. 4.2-4.4, 5, 6.2-6.5)	No such controls and instruments	N
12.2	RISK of poor USABILITY, including identification, marking, and documents addressed in a USABILITY ENGINEERING.....:	See Report based on IEC 60601-1-6	N
12.3	MANUFACTURER implemented an ALARM SYSTEM compliant with IEC 60601-1-8.:	No ALARM SYSTEM	N
12.4	Protection against hazardous output		N
12.4.1	RISKS associated with hazardous output arising from intentional exceeding of safety limits addressed in RISK MANAGEMENT PROCESS.....: (ISO 14971 Cl. 4.2-4.4, 5, 6.2-6.5)	No hazardous output	N
12.4.2	- need for indication associated with hazardous output addressed in RISK MANAGEMENT PROCESS...: (ISO 14971 Cl. 4.2-4.4, 5, 6.2-6.5)		N
12.4.3	RISKS associated with accidental selection of excessive output values for ME EQUIPMENT with a multi-purpose unit addressed in RISK MANAGEMENT PROCESS.....: (ISO 14971 Cl. 4.2-4.4, 5, 6.2-6.5)		N
12.4.4	RISKS associated with incorrect output addressed in RISK MANAGEMENT PROCESS.....: (ISO 14971 Cl. 4.2-4.4, 5, 6.2-6.5)		N
12.4.5	Diagnostic or therapeutic radiation		N
12.4.5.1	Adequate provisions to protect OPERATORS, PATIENTS, other persons and sensitive devices in vicinity of unwanted or excessive radiation	No diagnostic or therapeutic radiation	N

IEC 60601-1			
Clause	Requirement + Test	Result - Remark	Verdict
	Radiation safety ensured by compliance with requirements of appropriate standards		N
12.4.5.2	ME EQUIPMENT and ME SYSTEMS designed to produce X-radiation for diagnostic imaging purposes complied with IEC 60601-1-3..... :		N
12.4.5.3	RISKS associated with radiotherapy addressed in RISK MANAGEMENT PROCESS as : (ISO 14971 Cl. 4.2-4.4, 5, 6.2-6.5)		N
12.4.5.4	RISKS associated with ME EQUIPMENT producing diagnostic or therapeutic radiation other than diagnostic X-rays and radiotherapy addressed in RISK MANAGEMENT PROCESS as : (ISO 14971 Cl. 4.2-4.4, 5, 6.2-6.5)		N
12.4.6	RISKS associated with diagnostic or therapeutic acoustic pressure addressed in RISK MANAGEMENT : (ISO 14971 Cl. 4.2-4.4, 5, 6.2-6.5)		N

13	HAZARDOUS SITUATIONS AND FAULT CONDITIONS		P
13.1	Specific HAZARDOUS SITUATIONS		P
13.1.2	Emissions, deformation of ENCLOSURE or exceeding maximum temperature		P
	– Emission of flames, molten metal, poisonous or ignitable substance in hazardous quantities did not occur		P
	– Deformation of ENCLOSURE impairing compliance with 15.3.1 did not occur		P
	– Temperatures of APPLIED PARTS did not exceed allowable values in Table 24 :	See appended Table 11.1.1	P
	– Temperatures of ME EQUIPMENT parts that are not APPLIED PARTS likely to be touched did not exceed values in Table 23..... :	See appended Table 11.1.1	P
	–Allowable values for “other components and materials” in Table 22 times 1.5 minus 12.5 °C were not exceeded		P
	Limits for windings in Tables 26, 27, and 31 not exceeded		P
	Table 22 not exceeded in all other cases		P
	After tests of this Clause, settings of THERMAL CUT-OUTS and OVER-CURRENT RELEASES did not change sufficiently to affect their safety function		N
13.1.3	– limits for LEAKAGE CURRENT in SINGLE FAULT CONDITION did not exceed :	See appended Table 8.7	P
	– voltage limits for ACCESSIBLE PARTS including APPLIED PARTS did not exceed..... :	See appended Table 8.7	P
13. 2	SINGLE FAULT CONDITIONS		P
13.2.1	During the application of the SINGLE FAULT CONDITIONS listed in 13.2.2 to 13.2.13 (inclusive), the NORMAL CONDITIONS identified in 8.1 a) also applied in the least favourable combination		P

IEC 60601-1			
Clause	Requirement + Test	Result - Remark	Verdict
	ME EQUIPMENT complied with 13.2.2 -13.2.12	See appended Table 13.2	P
	RISK MANAGEMENT FILE includes and assessment of RISKS associated with leakage of liquid in a SINGLE FAULT CONDITION.....: (ISO 14971 Cl. 4.2-4.4, 5, 6.2-6.5)	No liquid leakage RISK	N
	RISK MANAGEMENT FILE defines the appropriate test conditions.....:		N
13.2.13	ME EQUIPMENT remained safe after tests of 13.2.13.2 to 13.2.13.4, and cooling down to within 3 °C of the temperature in the test environment		N
	ME EQUIPMENT examined for compliance or appropriate tests such as dielectric strength of motor insulation according to 8.8.3 conducted		N
	For insulation of thermoplastic materials relied upon as a MEANS OF PROTECTION, the ball-pressure test specified in 8.8.4.1 a) performed at a temperature 25 °C higher than temperature of insulation measured during tests of 13.2.13.2 to 13.2.13.4 (inclusive).		N
13.2.13.2	ME EQUIPMENT with heating elements		N
	a 1) thermostatically controlled ME EQUIPMENT with heating elements for building-in, r for unattended operation, or with a capacitor not protected by a fuse connected in parallel with THERMOSTAT contacts met tests	No heating elements	N
	a 2) ME EQUIPMENT with heating elements RATED for non-CONTINUOUS OPERATION met tests		N
	a 3) other ME EQUIPMENT with heating elements met test		N
	When more than one test was applicable to same ME EQUIPMENT, tests performed consecutively		N
	Heating period stopped when a heating element or an intentionally weak part of a non-SELF-RESETTING THERMAL CUT-OUT ruptured, or current interrupted before THERMAL STABILITY without possibility of automatic restoration		N
	Test repeated on a second sample when interruption was due to rupture of a heating element or an intentionally weak part		N
	Both samples met 13.1.2, and open circuiting of a heating element or an intentionally weak part in second sample not considered a failure by itself		N
	b) ME EQUIPMENT with heating elements without adequate heat discharge, and supply voltage set at 90 or 110 % of RATED supply voltage, least favourable of the two (V)..... :		N

IEC 60601-1			
Clause	Requirement + Test	Result - Remark	Verdict
	Operating period stopped when a non-SELF-RESETTING THERMAL CUT-OUT operated, or current interrupted without possibility of automatic restoration before THERMAL STABILITY		N
	ME EQUIPMENT switched off as soon as THERMAL STABILITY established and allowed to cool to room temperature when current not interrupted		N
	Test duration was equal to RATED operating time for non-CONTINUOUS OPERATION		N
	c) Heating parts of ME EQUIPMENT tested with ME EQUIPMENT operated in NORMAL CONDITION at 110 % of RATED supply voltage and as in 11.1, and		N
	1) Controls limiting temperature in NORMAL CONDITION disabled, except THERMAL CUT-OUTS		N
	2) When more than one control provided, they were disabled in turn		N
	3) ME EQUIPMENT operated at RATED DUTY CYCLE until THERMAL STABILITY achieved, regardless of RATED operating time		N
13.2.13.3	ME EQUIPMENT with motors		N
	a 1) For the motor part of the ME EQUIPMENT, compliance checked by tests of 13.2.8- 13.2.10, 13.2.13.3 b), 13.2.13.3 c), and 13.2.13.4, as applicable		N
	To determine compliance with 13.2.9 and 13.2.10 motors in circuits running at 42.4 V peak a.c./ 60 V d.c. or less are covered with a single layer of cheesecloth which did not ignite during the test		N
	a 2) Tests on ME EQUIPMENT containing heating parts conducted at prescribed voltage with motor & heating parts operated simultaneously to produce the least favourable condition		N
	a 3) Tests performed consecutively when more tests were applicable to the same ME EQUIPMENT		N
	b) Motor met running overload protection test of this clause when:		N
	1) it is intended to be remotely or automatically controlled by a single control device with no redundant protection, or		N
	2) it is likely to be subjected to CONTINUOUS OPERATION while unattended		N
	Motor winding temperature determined during each steady period and maximum value did not exceed Table 27 (Insulation Class, Maximum temperature measured °C)		N
	Motor removed from ME EQUIPMENT and tested separately when load could not be changed in appropriate steps		N

IEC 60601-1			
Clause	Requirement + Test	Result - Remark	Verdict
	Running overload test for motors operating at 42.4 V peak a.c./60 V d.c. or less performed only when examination and review of design indicated possibility of an overload		N
	Test not conducted where electronic drive circuits maintained a substantially constant drive current		N
	Test not conducted based on other justifications (justification)..... :		N
	c) ME EQUIPMENT with 3-phase motors operated with normal load, connected to a 3-phase SUPPLY MAINS with one phase disconnected, and periods of operation per 13.2.10		N
13.2.13.4	ME EQUIPMENT RATED for NON-CONTINUOUS OPERATION		N
	ME EQUIPMENT (other than HAND-HELD) operated under normal load and at RATED voltage or at upper limit of RATED voltage range until increase in temperature was ≤ 5 °C in one hour, or a protective device operated	Continuous operation	N
	When a load-reducing device operated in NORMAL USE, test continued with ME EQUIPMENT running idle		N
	Motor winding temperatures did not exceed values in 13.2.10		N
	Insulation Class		—
	Maximum temperature measured (°C)		—

14	PROGRAMMABLE ELECTRICAL MEDICAL SYSTEMS (PEMS)		P
14.1	Requirements of this clause not applied to PESS when it provided no BASIC SAFETY or ESSENTIAL PERFORMANCE, or		P
	- when application of RISK MANAGEMENT showed that failure of PESS does not lead to unacceptable RISK		N
	RISK MANAGEMENT FILE contains an assessment of RISKS associated with the failure of the PESS: (ISO 14971 Cl. 4.2-4.4, 5)		N
	Requirements of 14.13 not applied to PEMS intended to be incorporated into an IT NETWORK		N
	Software development process for Software Classification applied in accordance with Clause 4.3 of IEC 62304..... :	Refer to <YMDK-C101H1-RE-001/A0>	P
	Software development process applied according to Clause 5 of IEC 62304..... :	Refer to <YMDK-C101H1-RE-001/A0>	P
	Software development process for Software risk management applied according to Clause 7 of IEC 62304..... :	Refer to <YMDK-C101H1-RE-001/A0>	P

IEC 60601-1			
Clause	Requirement + Test	Result - Remark	Verdict
	Software development process Configuration Management applied according to Clause 8 of IEC 62304	Refer to <YMDK-C101H1-RE-001/A0>	P
	Software development process for Software Problem Resolution applied according to Clause 9 of IEC 62304	Refer to <YMDK-C101H1-RE-001/A0>	P
14.2	Documents required by Clause 14 reviewed, approved, issued and revised according to a formal document control process	Inspected	P
14.3	RISK MANAGEMENT plan required by 4.2.2 includes reference to PEMS VALIDATION plan		P
14.4	A PEMS DEVELOPMENT LIFE-CYCLE including a set of defined milestones has been documented		P
	At each milestone, activities to be completed, and VERIFICATION methods to be applied to activities have been defined		P
	Each activity including its inputs and outputs defined, and each milestone identifies RISK MANAGEMENT activities that must be completed before that milestone		P
	PEMS DEVELOPMENT LIFE-CYCLE tailored for a specific development by making plans detailing activities, milestones, and schedules		P
	PEMS DEVELOPMENT LIFE-CYCLE includes documentation requirements		P
14.5	A documented system for problem resolution within and between all phases and activities of PEMS DEVELOPMENT LIFE-CYCLE has been developed and maintained		N
14.6	RISK MANAGEMENT PROCESS		P
14.6.1	MANUFACTURER considered HAZARDS associated with software and hardware aspects of PEMS including those associated with the incorporating PEMS into an IT-NETWORK, components of third-party origin, legacy subsystems when compiling list of known or foreseeable HAZARDS	See below	P
	RISK MANAGEMENT FILE includes known or foreseeable HAZARDS associated with software, hardware, incorporation of the PEMS into an IT-NETWORK, components of 3rd party origin and legacy subsystems..... (ISO 14971 Cl. 4.3)	RMF Reference to specific RISKS: YMDK-RD-C101H1-0002/A0 (ISO 14971 Cl. 4.3)	P
14.6.2	Suitably validated tools and PROCEDURES assuring each RISK CONTROL measure reduces identified RISK(S) satisfactorily provided in addition to PEMS requirements in Clause 4.2.2.....	See below	P

IEC 60601-1			
Clause	Requirement + Test	Result - Remark	Verdict
	RISK MANAGEMENT FILE documents the suitability of tools and procedures to validate each RISK CONTROL measure.....: (ISO 14971 Cl. 6.1)	RMF Reference to specific RISKS: YMDK-RD-C101H1-0007/A0 (ISO 14971 Cl. 6.3)	P
14.7	A documented requirement specification for PEMS and each of its subsystems (e.g. for a PESS) which includes ESSENTIAL PERFORMANCE and RISK CONTROL measures implemented by that system or subsystem..... : (ISO 14971 Cl. 6.3)	RMF Reference to specific RISKS: YMDK-RD-C101H1-0007/A0 (ISO 14971 Cl. 6.3)	P
14.8	An architecture satisfying the requirement is specified for PEMS and each of subsystems : (ISO 14971 Cl. 6.3)	RMF Reference to specific RISKS: YMDK-RD-C101H1-0007/A0 (ISO 14971 Cl. 6.3)	P
14.9	Design is broken up into sub systems and descriptive data on design environment documented..... : (ISO 14971 Cl. 6.3)	Refer to <YMDK-RD-C101H1-017/A0>	P
14.10	A VERIFICATION plan containing the specified information used to verify and document functions implementing BASIC SAFETY, ESSENTIAL PERFORMANCE, or RISK CONTROL measures..... : (ISO 14971 Cl. 6.3)	RMF Reference to specific RISKS: YMDK-RD-C101H1-0007/A0 (ISO 14971 Cl. 6.3)	P
	– milestone(s) when VERIFICATION is to be performed for each function		P
	– selection and documentation of VERIFICATION strategies, activities, techniques, and appropriate level of independence of the personnel performing the VERIFICATION		P
	– selection and utilization of VERIFICATION tools		P
	– coverage criteria for VERIFICATION		P
	The VERIFICATION performed according to the VERIFICATION plan and results of the VERIFICATION activities documented	Refer to <YMDK-RD-C101H1-017/A0>	P
14.11	A PEMS VALIDATION plan containing validation of BASIC SAFETY & ESSENTIAL PERFORMANCE : (ISO 14971 Cl. 6.3)	Refer to < YMDK-RD-C101H1-0003/A0>	P
	The PEMS VALIDATION performed according to the PEMS VALIDATION plan with results of PEMS VALIDATION activities and methods used for PEMS VALIDATION documented		P
	The person with overall responsibility for PEMS VALIDATION is independent		P
	All professional relationships of members of PEMS VALIDATION team with members of design team documented in RISK MANAGEMENT FILE (ISO 14971 Cl. 6.3)	RMF Reference to specific RISKS: YMDK-RD-C101H1-0007/A0 (ISO 14971 Cl. 6.3)	P
14.12	Continued validity of previous design documentation assessed under a documented modification/change PROCEDURE		P

IEC 60601-1			
Clause	Requirement + Test	Result - Remark	Verdict
	Software Classification for Software changes applied in accordance with Clause 4.3 of IEC 62304..... :	Refer to <YMDK-C101H1-RE-001/A0>	P
	Software Process for Software changes applied according to Clause 5 of IEC 62304..... :	Refer to <YMDK-C101H1-RE-001/A0>	P
	RISK MANAGEMENT for Software changes applied according to Clause 7 of IEC 62304..... :	Refer to <YMDK-C101H1-RE-001/A0>	P
	Configuration management of software changes applied per Clause 8 of IEC 62304..... :	Refer to <YMDK-C101H1-RE-001/A0>	P
	Problem resolution for Software changes applied according to Clause 9 of IEC 62304..... :	Refer to <YMDK-C101H1-RE-001/A0>	P
14.13	For PEMS incorporated into an IT-NETWORK not VALIDATED by the PEMS MANUFACTURER, instructions made available for implementing the connection include the following		N
	a) Purpose of the PEMS connection to an IT-NETWORK		N
	b) required characteristics of the IT-NETWORK		N
	c) required configuration of the IT-NETWORK		N
	d) technical specifications of the network connection, including security specifications		N
	e) intended information flow between the PEMS, the IT-NETWORK and other devices on the IT-NETWORK, and the intended routing through the IT-NETWORK		N
	f) a list of HAZARDOUS SITUATIONS resulting from failure of the IT-NETWORK to provide the characteristics required (ISO 14971 Cl. 4.2-4.4, 5, 6.2-6.3)		N
	ACCOMPANYING DOCUMENTS for the RESPONSIBLE ORGANIZATION include the following:		N
	– statement that connection to IT-NETWORKS including other equipment could result in previously unidentified RISKS TO PATIENTS, OPERATORS or third parties		N
	– Notification that the RESPONSIBLE ORGANIZATION should identify, analyse, evaluate and control these RISKS		N
	– Notification that changes to the IT-NETWORK could introduce new RISKS that require additional analysis		N
	- Changes to the IT-NETWORK include: - changes in network configuration - connection of additional items - disconnection of items - update of equipment - upgrade of equipment		N

IEC 60601-1			
Clause	Requirement + Test	Result - Remark	Verdict
15	CONSTRUCTION OF ME EQUIPMENT		P
15.1	RISKS associated with arrangement of controls and indicators of ME EQUIPMENT addressed through the application of a USABILITY ENGINEERING PROCESS.. :	See IEC60601-1-6 report	N
15.2	Parts of ME EQUIPMENT subject to mechanical wear, electrical, environmental degradation or ageing resulting in unacceptable RISK when unchecked for a long period, are accessible for inspection, replacement, and maintenance		P
	Inspection, servicing, replacement, and adjustment of parts of ME EQUIPMENT can easily be done without damage to or interference with adjacent parts or wiring		P
15.3	Mechanical strength		P
15.3.1	Mould stress relief, push, impact, drop, and rough handling tests did not result in loss of BASIC SAFETY or ESSENTIAL PERFORMANCE		P
15.3.2	Push test conducted	See Appended Table 15.3	P
	No damage resulting in an unacceptable RISK sustained		P
15.3.3	Impact test conducted..... :		N
	No damage resulting in an unacceptable RISK sustained		N
15.3.4	Drop test		P
15.3.4.1	Sample of HAND-HELD ME EQUIPMENT, ACCESSORIES and HAND-HELD part with SAFE WORKING LOAD tested	See Appended Table 15.3	P
	No unacceptable RISK resulted		P
15.3.4.2	Sample of PORTABLE ME EQUIPMENT, ACCESSORIES and PORTABLE part with SAFE WORKING LOAD withstood stress as demonstrated by test	HAND-HELD ME EQUIPMENT	N
	No damage resulting in an unacceptable RISK sustained		N
15.3.5	MOBILE ME EQUIPMENT and MOBILE part with SAFE WORKING LOAD and in most adverse condition in NORMAL USE passed Rough Handling tests..... :	No mobile me equipment	N
	No damage resulting in an unacceptable RISK sustained		N
15.3.6	Examination of ENCLOSURE made from moulded or formed thermoplastic material indicated that material distortion due to release of internal stresses by moulding or forming operations will not result in an unacceptable RISK		P

IEC 60601-1			
Clause	Requirement + Test	Result - Remark	Verdict
	Mould-stress relief test conducted by placing one sample of complete ME EQUIPMENT, ENCLOSURE or a portion of larger ENCLOSURE, for 7 hours in a circulating air oven at 10°C over the max temperature measured on ENCLOSURE in 11.1.3, but no less than 70 °C	See Appended Table 15.3	P
	No damage resulting in an unacceptable RISK		P
15.3.7	INTENDED USE, EXPECTED SERVICE LIFE, and conditions for transport and storage were taken into consideration for selection and treatment of materials used in construction of ME EQUIPMENT		P
	Based on review of EQUIPMENT, ACCOMPANYING DOCUMENTS, specifications and processing of materials, and MANUFACTURER'S relevant tests or calculations, corrosion, ageing, mechanical wear, degradation of biological materials due to bacteria, plants, animals and the like, will not result in an unacceptable RISK		P
15.4	ME EQUIPMENT components and general assembly		P
15.4.1	Incorrect connection of accessible connectors, removable without a TOOL, prevented where an unacceptable RISK exists,..... : (ISO 14971 Cl. 4.2-4.4, 5, 6.2-6.5)	No such risks	N
	a) Plugs for connection of PATIENT leads or PATIENT cables cannot be connected to outlets on same ME EQUIPMENT intended for other functions, :		N
	b) Medical gas connections on ME EQUIPMENT for different gases to be operated in NORMAL USE are not interchangeable inspection	No gas connections	N
15.4.2	Temperature and overload control devices		N
15.4.2.1	a) THERMAL CUT-OUTS and OVER-CURRENT RELEASES with automatic resetting not used in ME EQUIPMENT when their use could lead to a HAZARDOUS SITUATION..... : (ISO 14971 Cl. 4.2-4.4, 5)	No temperature and overload control devices	N
	b) THERMAL CUT-OUTS with a safety function with reset by a soldering not fitted in ME EQUIPMENT		N
	c) An additional independent non-SELF-RESETTING THERMAL CUT-OUT is provided..... : (ISO 14971 Cl. 4.2-4.4)		N
	d) Operation of THERMAL CUT-OUT or OVER CURRENT RELEASE doesn't result in a HAZARDOUS SITUATION or loss of ESSENTIAL PERFORMANCE		N
	e) Capacitors or other spark-suppression devices not connected between contacts of THERMAL CUT-OUTS		N

IEC 60601-1			
Clause	Requirement + Test	Result - Remark	Verdict
	f) Use of THERMAL CUT-OUTS or OVER-CURRENT RELEASES do not affect safety as verified by following tests:		N
	- Positive temperature coefficient devices) complied with IEC 60730-1: 2010, Clauses 15, 17, J.15, and J.17		N
	- ME EQUIPMENT containing THERMAL CUT-OUTS and OVER-CURRENT RELEASES operated under the conditions of Clause 13		N
	- SELF-RESETTING THERMAL CUT-OUTS and OVER-CURRENT RELEASES including circuits performing equivalent functions Certified according to appropriate standards.....		N
	- In the absence of Certification in accordance with IEC standards, SELF-RESETTING THERMAL CUT-OUTS and OVER-CURRENT RELEASES including circuits performing equivalent functions operated 200 times		N
	Manual reset THERMAL CUT-OUTS and OVER-CURRENT RELEASES Certified in accordance with appropriate IEC standards		N
	manual reset THERMAL CUT-OUTS and OVER-CURRENT RELEASES operated 10 times		N
	Thermal protective devices tested separately from ME EQUIPMENT when engineering judgment indicated test results would not be impacted		N
	g) Protective device incorporating a fluid filled container with heating means, operated when heater switched on with container empty and prevented an unacceptable RISK due to overheating		N
	h) ME EQUIPMENT with tubular heating elements provided with protection against overheating : (ISO 14971 Cl. 4.2-4.4)		N
15.4.2.2	Temperature settings clearly indicated when means provided to vary setting of THERMOSTATS		N
15.4.3	Batteries		P
15.4.3.1	Battery housings provided with ventilation : (ISO 14971 Cl. 4.2-4.4)	No such risks	N
	Battery compartments designed to prevent accidental short circuiting		P
15.4.3.2	Means provided to prevent incorrect connection of polarity :	Information related to correct connection of polarity marked in battery box and fool-proof design	P

IEC 60601-1			
Clause	Requirement + Test	Result - Remark	Verdict
	RISK MANAGEMENT FILE includes an assessment of RISKS associated with incorrect connection or replacement of batteries : (ISO 14971 Cl. 4.2-4.4)	RMF Reference to specific RISKS: YMDK-RD-C101H1-0005/A0 and YMDK-RD-C101H1-0002/A0 (ISO 14971 Cl. 4.2-4.4)	P
15.4.3.3	Overcharging of battery prevented by virtue of design :		N
	RISK MANAGEMENT FILE includes an assessment of RISKS associated with overcharging of batteries.. : (ISO 14971 Cl. 4.2-4.4)		N
15.4.3.4	Primary lithium batteries comply with IEC 80086-4	Primary alkaline battery used	N
	Secondary lithium batteries comply with IEC 62133		N
15.4.3.5	A properly RATED protective device provided within INTERNAL ELECTRICAL POWER SOURCE to protect against fire :	No such risk	N
	Protective device has adequate breaking capacity		N
	Justification for OVER-CURRENT RELEASES or FUSE exclusion is documented		P
	Short circuit test between the positive and negative poles of an INTERNAL ELECTRICAL POWER SOURCE between the output and protective device(s) omitted where 2 MOOPs provided, or		N
	Short circuit between the positive and negative poles of an INTERNAL ELECTRICAL POWER SOURCE between the output and protective device(s) does not result in any HAZARDOUS SITUATION		N
15.4.4	Indicator lights provided to indicate ME EQUIPMENT is ready for :	No indicator lights	N
	An additional indicator light provided on ME EQUIPMENT with a stand-by state or a warm-up state exceeding 15 s,	<5s	N
	Indicator lights provided on ME EQUIPMENT incorporating non-luminous heaters to indicate heaters are operational	No non-luminous heaters	N
	RISK MANAGEMENT FILE includes an assessment of RISKS associated with the use of indicator lights for EQUIPMENT incorporating non-luminous heaters .. : (ISO 14971 Cl. 4.2-4.4)		N
	Requirement not applied to heated stylus-pens for recording purposes		N
	Indicator lights provided on ME EQUIPMENT to indicate an output exists	No such hazards	N
	Colours of indicator lights complied with 7.8.1		P
	Charging mode visibly indicated		P

IEC 60601-1			
Clause	Requirement + Test	Result - Remark	Verdict
15.4.5	RISKS associated with pre-set controls addressed in RISK MANAGEMENT PROCESS..... : (ISO 14971 Cl. 4.2-4.4, 5, 6.2-6.5)	No pre-set controls	N
15.4.6	Actuating parts of controls of ME EQUIPMENT		P
15.4.6.1	a) Actuating parts cannot be pulled off or loosened during NORMAL USE		P
	b) Controls secured so that the indication of any scale always corresponds to the position of the control	No such hazards	N
	c) Incorrect connection prevented by adequate construction when it could be separated without use of a TOOL		N
	When torque values per Table 30 applied knobs did not rotate		N
	Tests conducted with no unacceptable RISK		N
15.4.6.2	Stops on rotating/ movable parts of controls are of adequate mechanical strength	No such hazards	N
	Torque values in Table 30 applied		N
	No unexpected change of the controlled parameter when tested		N
15.4.7	Cord-connected HAND-HELD and foot-operated control devices		N
15.4.7.1	a) HAND-HELD control devices of ME EQUIPMENT complied with 15.3.4.1	No cord-connected HAND-HELD and foot-operated control devices	N
	b) Foot-operated control device supported an actuating force of 1350 N in its position of NORMAL USE with no damage.....		N
15.4.7.2	Control device of HAND-HELD and foot-operated control devices turned in all possible abnormal positions and placed on a flat surface		N
	No unacceptable RISK caused by changing control setting when accidentally placed in an abnormal position		N
15.4.7.3	a) Foot-operated control device is at least rated IPX1		N
	b) ENCLOSURE of foot operated control devices containing electrical circuits is at least IPX6.....		N
15.4.8	Aluminium wires less than 16 mm ² in cross-sectional area are not used	No aluminium wires	N
15.4.9	a) Oil container in PORTABLE ME EQUIPMENT allows for expansion of oil and is adequately sealed	No oil container	N
	b) Oil containers in MOBILE ME EQUIPMENT sealed to prevent loss of oil during transport		N
	A pressure-release device operating during NORMAL USE is provided		N

IEC 60601-1			
Clause	Requirement + Test	Result - Remark	Verdict
	c) Partially sealed oil-filled ME EQUIPMENT and its parts provided with means for checking the oil level to detect leakage		N
	ME EQUIPMENT and technical description examined, and manual tests conducted to confirm compliance with above requirements		N
15.5	MAINS SUPPLY TRANSFORMERS OF ME EQUIPMENT and transformers providing separation in accordance with 8.5		N
15.5.1	Overheating		N
15.5.1.1	Transformers of ME EQUIPMENT are protected against overheating	No transformer	N
	During tests, windings did not open, no HAZARDOUS SITUATION occurred, and maximum temperatures of windings did not exceed values in Table 31		N
	Dielectric strength test conducted after short circuit and overload tests		N
15.5.1.2	Transformer output winding short circuited, and test continued until protective device operated or THERMAL STABILITY achieved		N
	Short circuit applied directly across output windings		N
15.5.1.3	Multiple overload tests conducted on windings		N
15.5.2	Transformers operating at a frequency above 1kHz tested according to clause 8.8.3.....		N
	Transformer windings provided with adequate insulation		N
	Dielectric strength tests were conducted		N
15.5.3	Transformers forming MEANS OF PROTECTION as required by 8.5 comply with		N
	- Means provided to prevent displacement of end turns		N
	- protective earth screens with a single turn have insulated overlap		N
	- Exit of wires from internal windings of toroid transformers protected with double sleeving		N
	- insulation between primary and secondary windings complies with 8.8.2		N
	- CREEPAGE DISTANCES and AIR CLEARANCE comply with 8.9.4		N
16	ME SYSTEMS		N
16.1	After installation or subsequent modification, ME SYSTEM didn't result in an unacceptable RISK	No me systems	N

IEC 60601-1			
Clause	Requirement + Test	Result - Remark	Verdict
	RISK MANAGEMENT FILE includes an assessment of RISKS associated with installation and modification of an ME SYSTEM.....: (ISO 14971 Cl. 4.2-4.4, 5)		N
	Only HAZARDS arising from combining various equipment to form a ME SYSTEM considered		N
	– ME SYSTEM provides the level of safety within the PATIENT ENVIRONMENT equivalent to ME EQUIPMENT complying with this standard		N
	– ME SYSTEM provides the level of safety outside PATIENT ENVIRONMENT equivalent to equipment complying with their respective IEC or ISO safety standards		N
	– tests performed in NORMAL CONDITION, except as specified		N
	– tests performed under operating conditions specified by MANUFACTURER of ME SYSTEM		N
	Safety tests previously conducted on individual equipment of ME SYSTEM according to relevant standards not repeated		N
	RISK MANAGEMENT methods used by MANUFACTURER of an ME SYSTEM reconfigurable by RESPONSIBLE ORGANIZATION or OPERATOR		N
	Non-ME EQUIPMENT used in ME SYSTEM complied with applicable IEC or ISO safety standards		N
	Equipment relying only on BASIC INSULATION for protection against electric shock not used in ME SYSTEM		N
16.2	ACCOMPANYING DOCUMENTS of an ME SYSTEM		N
	Documents containing all data necessary for ME SYSTEM to be used as intended by MANUFACTURER including a contact address accompany ME SYSTEM or modified ME SYSTEM		N
	ACCOMPANYING DOCUMENTS regarded as a part of ME SYSTEM		N
	a) ACCOMPANYING DOCUMENTS provided for each item of ME EQUIPMENT supplied by MANUFACTURER		N
	b) ACCOMPANYING DOCUMENTS provided for each item of non-ME EQUIPMENT supplied by MANUFACTURER		N
	c) the required information is provided:		N
	– specifications, instructions for use as intended by MANUFACTURER, and a list of all items forming the ME SYSTEM		N
	– instructions for installation, assembly, and modification of ME SYSTEM to ensure continued compliance with this standard		N

IEC 60601-1			
Clause	Requirement + Test	Result - Remark	Verdict
	– instructions for cleaning and, when applicable, disinfecting and sterilizing each item of equipment or equipment part forming part of the ME SYSTEM		N
	– additional safety measures to be applied during installation of ME SYSTEM		N
	– identification of parts of ME SYSTEM suitable for use within the PATIENT ENVIRONMENT		N
	– additional measures to be applied during preventive maintenance		N
	– a warning forbidding placement of MULTIPLE SOCKET-OUTLET, when provided and it is a separate item, on the floor		N
	– a warning indicating an additional MULTIPLE SOCKET-OUTLET or extension cord not to be connected to ME SYSTEM		N
	– a warning to connect only items that have been specified as part of ME SYSTEM or specified as being compatible with ME SYSTEM		N
	– maximum permissible load for any MULTIPLE SOCKET-OUTLET(S) used with ME SYSTEM		N
	– instructions indicating MULTIPLE SOCKET-OUTLETS provided with the ME SYSTEM to be used only for supplying power to equipment intended to form part of ME SYSTEM		N
	– an explanation indicating RISKS of connecting non-ME EQUIPMENT supplied as a part of ME SYSTEM directly to wall outlet when non-ME EQUIPMENT is intended to be supplied via a MULTIPLE SOCKET-OUTLET with a separating transformer		N
	– an explanation indicating RISKS of connecting any equipment supplied as a part of ME SYSTEM to MULTIPLE SOCKET-OUTLET		N
	– permissible environmental conditions of use for ME SYSTEM including conditions for transport and storage		N
	– instructions to OPERATOR not to, simultaneously, touch parts referred to in 16.4 and PATIENT		N
	d) the following instructions provided for use by RESPONSIBLE ORGANIZATION:		N
	– adjustment, cleaning, sterilization, and disinfection PROCEDURES		N
	– assembly of ME SYSTEMS and modifications during actual service life shall be evaluated based on the requirements of this standard		N
16.3	Instructions for use of ME EQUIPMENT intended to receive its power from other equipment in an ME SYSTEM, describe the other equipment to ensure compliance with these requirements		N

IEC 60601-1			
Clause	Requirement + Test	Result - Remark	Verdict
	Transient currents restricted to allowable levels for the specified IPS or UPS		N
	Technical description and installation instructions specify the actual transient currents where an IPS or UPS is not specified		N
16.4	Parts of non-ME EQUIPMENT in PATIENT ENVIRONMENT subject to contact by OPERATOR during maintenance, calibration, after removal of covers, connectors operated at a voltage \leq voltage in 8.4.2 c)		N
16.5	Safety measures incorporating a SEPARATION DEVICE applied when FUNCTIONAL CONNECTION between ME EQUIPMENT and other items of an ME SYSTEM or other systems can cause allowable values of LEAKAGE CURRENT to exceed		N
	SEPARATION DEVICE has dielectric strength, CREEPAGE and CLEARANCES required for one MEANS OF OPERATOR PROTECTION		N
	WORKING VOLTAGE was highest voltage across SEPARATION DEVICE during a fault condition, but not less than MAXIMUM MAINS VOLTAGE (V)		N
16.6	LEAKAGE CURRENTS		N
16.6.1	TOUCH CURRENT in NORMAL CONDITION did not exceed 100 μ A.....		N
	TOUCH CURRENT did not exceed 500 μ A in event of interruption of any non-PERMANENTLY INSTALLED PROTECTIVE EARTH CONDUCTOR		N
16.6.2	Current in PROTECTIVE EARTH CONDUCTOR of MULTIPLE SOCKET-OUTLET didn't exceed 5 mA.....		N
16.6.3	PATIENT LEAKAGE CURRENT and total PATIENT LEAKAGE CURRENT of ME SYSTEM in NORMAL CONDITION did not exceed values		N
16.7	ME SYSTEM complied with applicable requirements of Clause 9.....		N
16.8	Interruption and restoration power to the ME SYSTEM or any part of the ME SYSTEM did not result in a loss of BASIC SAFETY or ESSENTIAL PERFORMANCE		N
16.9	ME SYSTEM connections and wiring		N
16.9.1	Incorrect connection of accessible connectors, removable without a TOOL, prevented where unacceptable RISK can result		N
	RISK MANAGEMENT FILE includes an assessment of RISKS associated with plugs for connection of PATIENT leads or cables likely to be located in the PATIENT ENVIRONMENT..... (ISO 14971 Cl. 4.2-4.4, 5, 6.2-6.5)		N

IEC 60601-1			
Clause	Requirement + Test	Result - Remark	Verdict
	– Plugs for connection of PATIENT leads or PATIENT cables could not be connected to other outlets of the same ME SYSTEM likely to be located in PATIENT ENVIRONMENT, except when examination of connectors and interchanging them proved no unacceptable RISK results		N
	Medical gas connections on the ME SYSTEM for different gasses operated in NORMAL USE are not interchangeable		N
16.9.2	MAINS PARTS, components and layout		N
16.9.2.1	a) – MULTIPLE SOCKET-OUTLET only allows connection using a TOOL, or		N
	– MULTIPLE SOCKET-OUTLET is of a type that cannot accept MAINS PLUGS of any of the kinds specified in IEC/TR 60083, or		N
	– MULTIPLE SOCKET-OUTLET is supplied via a separating transformer		N
	b) – MULTIPLE SOCKET-OUTLET marked with safety sign 2 of Table D.2 visible in NORMAL USE, and		N
	– marked either individually or in combinations, with the maximum allowed continuous output in amperes or volt-amperes, or		N
	– marked to indicate the equipment or equipment parts it may safely be attached to		N
	– MULTIPLE SOCKET-OUTLET is a separate item or an integral part of ME EQUIPMENT or non-ME EQUIPMENT		N
	c) MULTIPLE SOCKET-OUTLET complied with IEC 60884-1 and the following requirements:		N
	– CREEPAGE and CLEARANCES complied with 8.9		N
	– It is CLASS I, and PROTECTIVE EARTH CONDUCTOR is connected to earthing contacts in socket-outlets		N
	– PROTECTIVE EARTH TERMINALS and PROTECTIVE EARTH CONNECTIONS comply with 8.6:		N
	– ENCLOSURE complied with 8.4.2 d)		N
	– MAINS TERMINAL DEVICES and wiring complied with 8.11.4, when applicable		N
	– RATINGS of components are not in conflict with conditions of use		N
	– Electrical terminals and connectors of MULTIPLE SOCKET-OUTLETS prevent incorrect connection of accessible connectors removable without a TOOL		N
	– POWER SUPPLY CORD complied with 8.11.3		N
	d) Additional requirements applied when MULTIPLE SOCKET-OUTLET combined with a separating transformer:		N

IEC 60601-1			
Clause	Requirement + Test	Result - Remark	Verdict
	– Separating transformer complied with this standard or IEC 61558-2-1,		N
	– Separating transformer is CLASS I		N
	– Degree of protection against ingress of water specified as in IEC 60529		N
	– Separating transformer assembly marked according to 7.2 and 7.3		N
	– MULTIPLE SOCKET-OUTLET permanently connected to separating transformer, or socket-outlet of separating transformer assembly cannot accept MAINS PLUGS as identified in IEC/TR 60083		N
16.9.2.2	The impedance between the protective earth pin in the MAINS PLUG and any part that is PROTECTIVELY EARTHED did not exceed 200 mΩ		N
	Removal of any single item of equipment in ME SYSTEM will not interrupt the protective earthing of any other part without simultaneous disconnection of electrical supply to that part		N
	Additional PROTECTIVE EARTH CONDUCTORS can be detachable only by use of a TOOL		N
16.9.2.3	Conductors connecting different items within an ME SYSTEM protected against mechanical damage		N
17	ELECTROMAGNETIC COMPATIBILITY OF ME EQUIPMENT AND ME SYSTEMS		N
	RISKS associated confirmed by review	See IEC 60601-1-2 Report	N
	– electromagnetic phenomena at locations where ME EQUIPMENT or ME SYSTEM is to be used as stated in ACCOMPANYING DOCUMENTS.....		N
	RISK MANAGEMENT FILE includes an assessment of risks associated with the introduction of electromagnetic phenomena into the environment by the EQUIPMENT or SYSTEM..... (ISO 14971 Cl. 4.2-4.4, 5, 6.2-6.5)		N
	– introduction of electromagnetic phenomena into environment by ME EQUIPMENT or ME SYSTEM that might degrade performance of other devices, electrical equipment, and systems		N
ANNEX G	PROTECTION AGAINST HAZARDS OF IGNITION OF FLAMMABLE ANESTHETIC MIXTURES		N
G.2	Locations and basic requirements		N
G.2.1	Parts of CATEGORY APG ME EQUIPMENT in which a FLAMMABLE ANAESTHETIC MIXTURE WITH AIR occurs are CATEGORY AP or APG ME EQUIPMENT and complied with G.3, G.4, and G.5	No intended to be used in flammable anesthetic mixtures	N

IEC 60601-1			
Clause	Requirement + Test	Result - Remark	Verdict
G.2.2	FLAMMABLE AESTHETIC MIXTURE WITH		N
G.2.3	A FLAMMABLE AESTHETIC MIXTURE WITH OXYGEN OR NITROUS OXIDE		N
G.2.4	ME EQUIPMENT specified for use with FLAMMABLE AESTHETIC MIXTURE WITH AIR complied with G.4 and G.5		N
G.2.5	ME EQUIPMENT or parts thereof for use with FLAMMABLE AESTHETIC MIXTURE WITH OXYGEN OR NITROUS OXIDE comply with G.4 and G.6		N
	ME EQUIPMENT in G.2.4 to G.2.5 met appropriate tests of G.3-G.5 conducted after tests of 11.6.6 and 11.6.7		N
G.3	Marking, ACCOMPANYING DOCUMENTS		N
G.3.1	CATEGORY APG ME EQUIPMENT prominently marked "APG" (symbol 23 in Table D.1)		N
	Length of green-coloured band is ≥ 4 cm, and size of marking is as large as possible for particular case		N
	When above marking not possible, relevant information included in instructions for use		N
	Marking complied with tests and criteria of 7.1.2 and 7.1.3		N
G.3.2	CATEGORY AP ME EQUIPMENT prominently marked, with a green-coloured circle "AP" (symbol 22 in Table D.1)		N
	Marking is as large as possible for the particular case		N
	When above marking not possible, the relevant information included in instructions for use		N
	Marking complied with tests and criteria of 7.1.2 and 7.1.3		N
G.3.3	The marking placed on major part of ME EQUIPMENT for CATEGORY AP or APG parts		N
G.3.4	ACCOMPANYING DOCUMENTS contain an indication enabling the RESPONSIBLE ORGANIZATION to distinguish between CATEGORY AP and APG parts		N
G.3.5	Marking clearly indicates which parts are CATEGORY AP or APG when only certain ME EQUIPMENT parts are CATEGORY AP or APG		N
G.4	Common requirements for CATEGORY AP and CATEGORY APG ME EQUIPMENT		
G.4.1	a) CREEPAGE and CLEARANCES are according to Table 12 for one MEANS OF PATIENT PROTECTION		N
	b) Connections protected against accidental disconnection		N
	c) CATEGORY AP and APG not provided with a DETACHABLE POWER SUPPLY CORD,		N

IEC 60601-1			
Clause	Requirement + Test	Result - Remark	Verdict
G.4.2	Construction details		N
	a) Opening of an ENCLOSURE protecting against penetration of gases or vapours into ME EQUIPMENT or its parts possible only with a TOOL		N
	b) ENCLOSURE complies with..... :		N
	– no openings on top covers of ENCLOSURE,		N
	– openings in side-covers prevented penetration of a solid cylindrical test rod		N
	– openings in base plates prevented penetration of a solid cylindrical test		N
	c) Short circuiting conductor(s) to a conductive part (when no explosive gasses) did not result in loss of integrity of the part, an unacceptable temperature, or any HAZARDOUS SITUATION		N
G.4.3	a) Electrostatic charges prevented on CATEGORY AP and APG ME EQUIPMENT by a combination of appropriate measures		N
	– Use of antistatic materials with a limited electrical resistance	See appended Table 8.10	N
	– Provision of electrically conductive paths from ME EQUIPMENT or its parts to a conductive floor, protective earth or potential equalization system, or via wheels to an antistatic floor		N
	b) Electrical resistance limits of aesthetic tubing, mattresses/ pads, castor tires & other antistatic material comply with ISO 2882..... :		N
G.4.4	Corona cannot be produced by components or parts of ME EQUIPMENT operating at more than 2000 V a.c. or 2400 V d.c. and not included in ENCLOSURES complying with G.5.4 or G.5.5		N
G.5	Requirements and tests for CATEGORY AP ME EQUIPMENT, parts and components		N
G.5.1	ME EQUIPMENT, its parts or components do not ignite FLAMMABLE AESTHETIC MIXTURES WITH AIR under NORMAL USE and CONDITIONS based on compliance with G.5.2 to G.5.5		N
	Alternatively, ME EQUIPMENT, its parts, and components complied with requirements of IEC 60079-0 for pressurized ENCLOSURES (IEC 60079-2); for sand-filled ENCLOSURES, IEC 60079-5; or for oil immersed equipment, IEC 60079-6; and with this standard excluding G.5.2 to G.5.5		N
G.5.2	Temperature limits		N
G.5.3	ME EQUIPMENT, its parts, and components producing sparks in NORMAL USE and CONDITION complied with temperature requirements of G.5.2, and U_{max} and I_{max} occurring in their circuits, and complied as follows:		N
	Measured $U_{max} \leq U_{zR}$ with I_{zR} as in Fig. G.1		N

IEC 60601-1			
Clause	Requirement + Test	Result - Remark	Verdict
	Measured $U_{max} \leq U_c$ with C_{max} as in Fig. G.2		N
	Measured $I_{max} \leq I_{zR}$ with U_{zR} as in Fig G.1		N
	Measured $I_{max} \leq I_{zL}$ with L_{max} and a $U_{max} \leq 24$ V as in Fig G.3		N
	– Combinations of currents and corresponding voltages within the limitations $I_{zR} \cdot U_{zR} \leq 50$ W extrapolated from Fig G.1		N
	No extrapolation made for voltages above 42 V		N
	– Combinations of capacitances and corresponding voltages within limitations of $C/2U^2 \leq 1.2$ mJ extrapolated from Fig G.2		N
	No extrapolation made for voltages above 242V		N
	U_{max} determined using actual resistance R		N
	– Combinations of currents and corresponding inductances within limitations $L/2I^2 \leq 0.3$ mJ extrapolated from Fig G.3		N
	No extrapolation made for inductances larger than 900 mH		N
	– U_{max} was the highest supply voltage occurring in circuit under investigation with sparking contact open		N
	– I_{max} was the highest current flowing in circuit under investigation with sparking contact closed		N
	– C_{max} and L_{max} taken as values occurring at the component under investigation producing sparks		N
	– Peak value considered when a.c. supplied		N
	– An equivalent circuit calculated to determine equivalent max capacitance, inductance, and equivalent U_{max} and I_{max} , either as d.c. or a.c. peak values in case of a complicated circuit		N
	Temperature measurements made according to 11.1, and U_{max} , I_{max} , R, L_{max} , and C_{max} determined with application of Figs G.1-G.3		N
	Alternatively, compliance was verified by examination of design data		N
G.5.4	External ventilation with internal overpressure		N
	ME EQUIPMENT, its parts, and components enclosed in an ENCLOSURE with external ventilation by means of internal overpressure complied with the following requirements:		N
	a) FLAMMABLE AESTHETIC MIXTURES WITH AIR removed by ventilation before EQUIPMENT energized,		N
	b) Overpressure inside ENCLOSURE was 75 Pa, min., in NORMAL CONDITION (Pa)		N

IEC 60601-1			
Clause	Requirement + Test	Result - Remark	Verdict
	Overpressure maintained at the site of potential ignition		N
	ME EQUIPMENT could be energized only after the required minimum overpressure was present long enough to ventilate the ENCLOSURE		N
	ME EQUIPMENT energized at will or repeatedly when overpressure was continuously present		N
	c) Ignition sources de-energized automatically when during operation overpressure dropped below 50 Pa (Pa)		N
	d) External surface of ENCLOSURE did not exceed 150 °C in 25 °C		N
G.5.5	ENCLOSURES with restricted breathing		N
	ME EQUIPMENT, its parts, and components enclosed in an ENCLOSURE with restricted breathing complied with the following:		N
	a) A FLAMMABLE AESTHETIC MIXTURE WITH AIR did not form inside ENCLOSURE with restricted breathing		N
	b) Gasket or sealing material used to maintain tightness complied with aging test B-b of IEC 60068-2-2, Clause 15, at 70 °C ± 2 °C and 96 h..		N
	c) Gas-tightness of ENCLOSURE containing inlets for flexible cords maintained		N
	Cords are fitted with adequate anchorages to limit stresses as determined by test		N
	Overpressure not reduced below 200 Pa		N
	Tests waived when examination of ENCLOSURE indicated it is completely sealed or gas-tight without a doubt (100 % degree of certainty)		N
	Operating temperature of external surface of ENCLOSURE was ≤ 150 °C in 25 °C (°C)		N
	Steady state operating temperature of ENCLOSURE also measured (°C).....		N
G.6	CATEGORY APG ME EQUIPMENT, parts and components thereof		N
G.6.1	ME EQUIPMENT, its parts, and components did not ignite FLAMMABLE AESTHETIC MIXTURE WITH OXYGEN OR NITROUS OXIDE under NORMAL USE and SINGLE FAULT CONDITION		N
	ME EQUIPMENT, its parts, and components not complying with G.6.3 subjected to a CONTINUOUS OPERATION test		N
G.6.2	Parts and components of CATEGORY APG ME EQUIPMENT operating in a FLAMMABLE AESTHETIC MIXTURE WITH OXYGEN OR NITROUS OXIDE supplied from a source isolated from earth by insulation equal to one MEANS OF PATIENT PROTECTION and from electrical parts by insulation twice the MEANS OF PATIENT PROTECTION		N

IEC 60601-1			
Clause	Requirement + Test	Result - Remark	Verdict
G.6.3	Test of G.6.1 waived when the following requirements were met in NORMAL USE and under NORMAL and SINGLE FAULT CONDITIONS		N
	a) no sparks produced and temperatures did not exceed 90 °C, or		N
	b) a temperature limit of 90 °C not exceeded, sparks produced in NORMAL USE, and SINGLE FAULT CONDITIONS, except U_{max} and I_{max} occurring in their circuits complied with requirements, taking C_{max} and L_{max} into consideration:		N
	Measured $U_{max} \leq U_{zR}$ with I_{zR} as in Fig. G.4		N
	Measured $U_{max} \leq U_{zC}$ with C_{max} as in Fig. G.5		N
	Measured $I_{max} \leq I_{zR}$ with U_{zR} as in Fig G.4		N
	Measured $I_{max} \leq I_{zL}$ with L_{max} and a $U_{max} \leq 24$ V as in Fig G.6		N
	– Extrapolation from Figs G.4, G.5, and G.6 was limited to areas indicated		N
	– U_{max} was the highest no-load voltage occurring in the circuit under investigation, taking into consideration mains voltage variations as in 4.10		N
	– I_{max} was the highest current flowing in the circuit under investigation, taking into account MAINS VOLTAGE variations as in 4.10		N
	– C_{max} and L_{max} are values occurring in relevant circuit		N
	– U_{max} additionally determined with actual resistance R when equivalent resistance R in Fig G.5 was less than 8000 Ω		N
	– Peak value considered when a.c. supplied		N
	– An equivalent circuit calculated to determine max capacitance, inductance, and U_{max} and I_{max} , either as d.c. or a.c. peak values in case of a complicated circuit		N
	– When energy produced in an inductance or capacitance in a circuit is limited by voltage or current-limiting devices, two independent components applied, to obtain the required limitation even when a first fault (short or open circuit) in one of these components		N
	- requirement not applied to transformers complying with this standard		N
	- requirement not applied to wire-wound current-limiting resistors provided with a protection against unwinding of the wire in case of rupture		N
	Compliance verified by examination of CATEGORY APG ME EQUIPMENT, parts, and components , or		N

IEC 60601-1			
Clause	Requirement + Test	Result - Remark	Verdict
	Temperature measurements made in accordance with 11.1		N
	- or U_{max} , I_{max} , R, L_{max} and C_{max} determined together with application of Figs G.4-G.6		N
	Alternatively, compliance verified by comparison with design data		N
G.6.4	ME EQUIPMENT, its parts, and components heating a FLAMMABLE AESTHETIC MIXTURE WITH OXYGEN OR NITROUS OXIDE provided with a non-SELF-RESETTING THERMAL CUT-OUT and complied with 15.4.2.1		N
	Current-carrying part of heating element is not in direct contact with FLAMMABLE AESTHETIC MIXTURE WITH OXYGEN OR NITROUS OXIDE		N
G.7	Test apparatus for flammable mixtures according to this Clause and Fig G.7		N

ANNEX L			
INSULATED WINDING WIRES FOR USE WITHOUT INTERLEAVED INSULATION			N
L.1	BASIC, SUPPLEMENTARY, DOUBLE, and REINFORCED INSULATION in wound components without interleaved insulation complied with this Annex		N
L.2	Wire construction		N
	Overlap of layers when wire is insulated with two or more spirally wrapped layers of tape is adequate to ensure continued overlap during manufacture of wound component		N
	Layers of spirally wrapped wire insulation are sufficiently secured to maintain the overlap		N
L.3	Type Test		N
	The wire subjected to tests of L.3.1 to L.3.4 at a temperature and a relative humidity specified		N
	Temperature (°C)		—
	Humidity (%)		—
L.3.1	Dielectric strength		N
	Dielectric strength test of Clause 8.8.3 for the appropriate type and number of MOP(s) conducted with no breakdown:		N
	– 3000 V for BASIC and SUPPLEMENTARY INSULATION (V)		N
	– 6000 V for REINFORCED INSULATION (V)		N
L.3.2	Flexibility and adherence		N
	Sample subjected to flexibility and adherence		N
	Sample examined per IEC 60851-3: 1997, cl. 5.1.1.4, followed by dielectric test of cl. 8.8.3, with no breakdown		N

IEC 60601-1			
Clause	Requirement + Test	Result - Remark	Verdict
	Test voltage was at least the voltage in Tables 6 and 7 but not less than the following:		N
	– 1500 V for BASIC and SUPPLEMENTARY INSULATION (V)		N
	– 3000 V for REINFORCED INSULATION (V)		N
	Tension applied to wire during winding on mandrel calculated from the wire diameter equivalent to 118 MPa ± 11.8 MPa		N
L.3.3	Heat Shock		N
	Sample subjected to heat shock test 9 of IEC 60851-6:1996, followed by dielectric strength test of clause 8.8.3		N
	Test voltage was at least the voltage in Tables 6 and 7, but not less than the following:		N
	– 1500 V for BASIC and SUPPLEMENTARY INSULATION (V)		N
	– 3000 V for REINFORCED INSULATION (V)		N
	Oven temperature based on Table L.2 (°C)		—
	Mandrel diameter and tension applied as in clause L.3.2, (MPa; N/mm ²)		N
	Dielectric strength test conducted at room temperature after removal from the oven		N
L.3.4	Retention of electric strength after bending		N
	Five samples prepared as in L.3.2 subjected to dielectric strength and bending tests		N
	Test voltage was at least the voltage in Tables 6 and 7, but not less than the following:		N
	– 1500 V for BASIC and SUPPLEMENTARY INSULATION (V)		N
	– 3000 V for REINFORCED INSULATION (V)		N
	Test voltage applied between the shot and conductor		N
	Mandrel diameter and tension applied as in L.3.2, (MPa; N/mm ²)		N
L.4	Tests during manufacture		N
L.4.1	Production line dielectric strength tests done by the manufacture per L.4.2 and L.4.3		N
L.4.2	Test voltage for routine testing (100 % testing) is at least the voltage in Tables 6 and 7 but not less than the following:		N
	– 1500 V r.m.s. or 2100 V peak for BASIC and SUPPLEMENTARY INSULATION (V).....		N
	– 3000 V r.m.s. or 4200 V peak for REINFORCED INSULATION (V).....		N

IEC 60601-1			
Clause	Requirement + Test	Result - Remark	Verdict
L.4.3	Sampling tests conducted using twisted pair samples (IEC 60851-5:1996, clause 4.4.1)		N
	Minimum breakdown test voltage at least twice the voltage in Tables 6 and 7 but not less than:		N
	– 3000 V r.m.s. or 4200 V peak for BASIC and SUPPLEMENTARY INSULATION		N
	– 6000 V r.m.s. or 8400 V peak for REINFORCED INSULATION.....		N

IEC 60601-1			
Clause	Requirement + Test	Result - Remark	Verdict

ATTACHMENT TO TEST REPORT IEC 60601-1 US NATIONAL DIFFERENCES Medical electrical equipment, Part 1: General Requirements	
Differences according to	US National standard ANSI/AAMI ES 60601-1:2005/(R)2012 and A1:2012, C1:2009/(R)2012 and A2:2010/(R)2012
Attachment Form No.	US_ND_IEC60601_1H
Attachment Originator.....	Underwriters Laboratories Inc.

	US NATIONAL DIFFERENCES		P
4.8 b	Replacement: where there was no relevant IEC/ISO standard, the relevant US ANSI standard applied		P
	- when no relevant US ANSI standard existed, the requirements of this standard applied		P
4.10.2	Replacement: Rated voltage not exceeding 250V dc or single phase ac. or 600V poly-phase ac for ME EQUIPMENT and ME SYSTEMS up to 4kVA		N
	Rated voltage not exceeding 600 V for all other ME EQUIPMENT and ME SYSTEMS		N
6.6	Addition: To comply with NFPA 70, X-Ray systems are classified as long time operation (> 5 min) or momentary operation (< 5 sec)		N
7.2.11	Addition: To comply with NFPA 70, X-Ray systems are marked as long time operation or momentary operation		N
7.2.21	New Sub-clause: Colors of medical gas cylinders		N
	To comply with NFPA 99: Cylinders containing medical gases and their connection points are colored in accordance with the requirements of NFPA 99	No medical gas cylinders	N
8.2	Addition: All FIXED ME EQUIPMENT & PERMANENTLY INSTALLED ME EQUIPMENT are CLASS I ME EQUIPMENT	No FIXED ME EQUIPMENT & PERMANENTLY INSTALLED ME EQUIPMENT	N
8.6.1	Addition: To comply with NFPA 99, the enclosure of X-ray ME EQUIPMENT operating over 600 Vac, 850Vdc MAINS VOLTAGE, or containing voltages up to 50 V peak and enclosed in protectively earthed enclosure as well as connections to X-ray tubes and other high voltage components that include high voltage shielded cables are PROTECTIVELY EARTHED.		N
	To comply with NFPA 99, non-current carrying conductive parts of X-Ray ME EQUIPMENT likely to become energized are PROTECTIVELY EARTHED		N
8.7.3 d	EARTH LEAKAGE CURRENT values are not higher than the stated values	No PROTECTIVE EARTH CONNECTION	N
	5 mA in NORMAL CONDITION		N
	10 mA in SINGLE FAULT CONDITION		N

IEC 60601-1			
Clause	Requirement + Test	Result - Remark	Verdict
8.11	Addition prior to the first paragraph: a) To comply with the NEC, add the following requirements to this clause:		N
	Addition: PERMANENTLY CONNECTED ME EQUIPMENT provided with field wiring provision in accordance with NEC	No PERMANENTLY CONNECTED ME EQUIPMENT	N
	Installation of connecting cords between EQUIPMENT parts comply with NEC		N
	Cable used as external interconnection between units		N
	1) Exposed to abuse: Type SJT, SJTO, SJO, ST, SO, STO, or equivalent, or similar multiple-conductor appliance-wiring material,		N
	2) Not exposed to abuse: The cable was as in item 1) above, or		N
	i) Type SPT-2, SP-2, or SPE-2, or equivalent		N
	ii) Type SVr, SVRO, SVE, or equivalent or similar multiple-conductor appliance wiring material,		N
	iii) An assembly of insulated wires each with a nominal insulation thickness of 0.8 mm (1/32 inch) or more,		N
	- enclosed in acceptable insulating tubing having a nominal wall thickness of 0.8 mm (1/32 inch) or more		N
	Receptacles provided as part of ME EQUIPMENT and ME SYSTEMS for use in the patient care areas of pediatric wards, rooms, or areas are Listed tamper resistant		N
	- or employ a Listed tamper resistant cover in accordance with NEC		N
	Addition at the end of the clause: b) For ME EQUIPMENT provided with NEMA configuration non-locking plug types 120 V/15 A, 125 V/20 A, 250 V/15 A, 250 V/20 A "Hospital Grade" mains plug is provided and the POWER SUPPLY CORD is marked		N
8.11.3.2	Addition: The flexible cord is a type acceptable for the particular application,		N
	- and it is acceptable for use at a voltage not less than the rated voltage of the appliance		N
	- and has an ampacity as in NEC, not less than the current rating of the appliance		N
8.11.3.3	Addition: To comply with NFPA 99, for X-Ray ME EQUIPMENT with an attachment plug, the current rating on a hospital grade plug is 2X the maximum input current of the equipment		N

4.2.2	RM RESULTS TABLE: General requirements for RISK MANAGEMENT			P
Clause of ISO 14971	Document Ref. in RMF (Document No. paragraph/clause, version)		Result - Remarks	Verdict
	General process	Particular Medical Device		
3.1	YMDK-RD-C101H1-0001/A0, chapter 2	—	Risk Management Process	P
3.2	YMDK-RD-C101H1-0001/A0, chapter 2	—	Risk management process, adequate Resources	P
3.2	YMDK-RD-C101H1-0001/A0, chapter 3	—	Risk management process, assignment of qualified personnel	P
3.2	YMDK-RD-C101H1-0001/A0, chapter 4	—	Risk management process, policy for determining criteria for risk acceptability	P
3.3	—	YMDK-RD-C101H1-0001/A0, chapter 3	Qualification of personnel	P
3.4a	—	YMDK-RD-C101H1-0001/A0, chapter 5	Risk management plan	P
3.4b	—	YMDK-RD-C101H1-0001/A0, chapter 5	Risk management plan	P
3.4c	—	YMDK-RD-C101H1-0001/A0, chapter 5	Risk management plan	P
3.4d	—	YMDK-RD-C101H1-0001/A0, chapter 5	Risk management plan	P
3.4e	—	YMDK-RD-C101H1-0001/A0, chapter 5	Risk management plan	P
3.5	—	YMDK-RD-C101H1-0003/A0, Whole file	Risk management file	P
4.1	—	YMDK-RD-C101H1-0003/A0, chapter 2	Risk analysis process	P
4.2	—	YMDK-RD-C101H1-0005/A0, Whole file	Intended use and identification of characteristics related to the safety of medical device	P
4.3	—	YMDK-RD-C101H1-0002/A0, Whole file	Identification of hazards	P
4.4	—	YMDK-RD-C101H1-0002/A0, Whole file	Estimation of risk(s) for each hazardous situation	P
5	—	YMDK-RD-C101H1-0007/A0, Whole file	Risk evaluation	P
6.2	—	YMDK-RD-C101H1-0007/A0, Whole file	Risk control option analysis	P
6.3	—	YMDK-RD-C101H1-0007/A0, Whole file	Implementation of risk control measure(s)	P
6.4	—	YMDK-RD-C101H1-0007/A0, Whole file	Residual risk evaluation	P
6.5	—	No further risk/ benefit analysis required	Risk/ benefit analysis	N
6.6a	—	No new hazards introduced	Risks arising from risk control measures	N

4.2.2	RM RESULTS TABLE: General requirements for RISK MANAGEMENT			P
Clause of ISO 14971	Document Ref. in RMF (Document No. paragraph/clause, version)		Result - Remarks	Verdict
	General process	Particular Medical Device		
6.6b	—	No new hazards introduced	Risks arising from risk control measures	N
6.7	—	YMDK-RD-C101H1-0003/A0, chapter 3	Completeness of risk control	N
7	—	YMDK-RD-C101H1-0003/A0, chapter 3	Evaluation of overall residual risk acceptability	P
8	—	YMDK-RD-C101H1-0003/A0, Whole file	Risk management report	P

Supplementary Information:
Document Ref should be with regards to the policy/procedure documents and documents containing device specific output.

4.3	TABLE: ESSENTIAL PERFORMANCE		P
List of ESSENTIAL PERFORMANCE functions	MANUFACTURER'S document number reference or reference from this standard or collateral or particular standard(s)	Remarks	
SpO2 and pulse measurement	ISO 80601-2-61		

Supplementary Information:
ESSENTIAL PERFORMANCE is performance, the absence or degradation of which, would result in an unacceptable risk.

4.11	TABLE: Power Input					N
Operating Conditions / Ratings	Voltage (V)	Frequency (Hz)	Current (A)	Power (W)	Power factor (cos φ)	

Supplementary Information:

5.9.2	TABLE: Determination of ACCESSIBLE parts		P
Location	Determination method (NOTE1)	Comments	
Enclosure	Visual	No safety hazards	
Screen	Visual	No safety hazards	
Functional button	Visual	No safety hazards	

Supplementary information:
NOTE 1 - The determination methods are: visual; rigid test finger; jointed test finger; test hook.

7.1.2	TABLE: Legibility of Marking		P
Markings tested	Ambient Illuminance (lx)	Remarks	
Outside Markings (Clause 7.2)	500	clearly visible	
Inside Markings (Clause 7.3)	500	clearly visible	
Controls & Instruments (Clause 7.4)	500	clearly visible	
Safety Signs (Clause 7.5)	500	--	
Symbols (Clause 7.6)	500	clearly visible	
Supplementary information:			
Observer, with a visual acuity of 0 on the log Minimum Angle of Resolution (log MAR) scale or 6/6 (20/20) and is able to read N6 of the Jaeger test card in normal room lighting condition (~500lx), reads marking at ambient illuminance least favourable level in the range of 100 lx to 1,500 lx. The ME EQUIPMENT or its part was positioned so that the viewpoint was the intended position of the OPERATOR or if not defined at any point within the base of a cone subtended by an angle of 30° to the axis normal to the centre of the plane of the marking and at a distance of 1 m.			

7.1.3	TABLE: Durability of marking test		P
Characteristics of the Marking Label tested:			Remarks
Material of Marking Label	Polyester label		-
Ink/other printing material or process	Ink		-
Material (composition) of Warning Label	Polyester label		-
Ink/other printing material or process	Ink		-
Other	Polyester label		-
Marking Label Tested:			Remarks
Marking plate			-
Supplementary information:			
Marking rubbed by hand, first for 15 s with a cloth rag soaked with distilled water, then for 15 s with a cloth rag soaked with ethanol 96%, and then for 15 s with a cloth rag soaked with isopropyl alcohol.			

8.4.2	TABLE: TABLE: Working Voltage / Power Measurement					N
Test supply voltage/frequency (V/Hz) ¹						
Location From/To	Measured values					Remarks
	Vrms	Vpk or Vdc	Peak-to-peak ripple ²	Power W/VA	Energy (J)	
Supplementary Information:						
1. The input supply voltage to the ME EQUIPMENT was the RATED voltage or the voltage within the RATED voltage range which results in the highest measured value. See clause 8.5.4.						
2. If the d.c peak-to-peak ripple >10%, waveform considered as a.c. See clause 8.4.2.2						

8.4.3	TABLE: ME EQUIPMENT for connection to a power source by a plug - measurement of voltage or calculation of stored charge 1 s after disconnection of plug from mains supply									N
Maximum allowable voltage (V)									60	
Voltage measured (V)										
Voltage Measured Between:	1	2	3	4	5	6	7	8	9	10
Plug pins 1 and 2										
Plug pin 1 and plug earth pin										
Plug pin 2 and plug earth pin										
Plug pin 1 and enclosure										
Plug pin 2 and enclosure										
Maximum allowable stored charge when measured voltage exceeded 60 v (μC)									45	
Calculated stored charge (μC)										
Voltage Measured Between:	1	2	3	4	5	6	7	8	9	10
Plug pins 1 and 2										
Plug pin 1 and plug earth pin										
Plug pin 2 and plug earth pin										
Plug pin 1 and enclosure										
Plug pin 2 and enclosure										
Supplementary information:										

8.4.4	TABLE: Internal capacitive circuits – measurement of residual voltage or calculation of the stored charge in capacitive circuits (i.e., accessible capacitors or circuit parts) after de-energizing me equipment			N
Maximum allowable residual voltage (V):				60 V
Maximum allowable stored charge when residual voltage exceeded 60 V :				45 μC
Description of the capacitive circuit (i.e., accessible capacitor or circuit parts)	Measured residual voltage (V)	Calculated stored charge (μC)	Remarks	
Supplementary information:				

8.5.5.1a	TABLE: defibrillation-proof applied parts – measurement of hazardous electrical energies				N
Test Condition: Figs. 9 & 10	Measurement made on accessible part	Applied part with test voltage	Test voltage polarity	Measured voltage between Y1 and Y2 (mV)	Remarks
Figs. 9					
Figs. 10					
Supplementary information:					

8.5.5.1b	TABLE: defibrillation-proof applied parts – verification of recovery time				N
Applied part with test voltage	Test voltage polarity	Recovery time from documents (s)	Measured recovery time (s)	Remarks	
Supplementary information:					

8.5.5.2	TABLE: DEFIBRILLATION-PROOF APPLIED PARTS OR PATIENT CONNECTIONS of DEFIBRILLATION-PROOF APPLIED PARTS - Energy reduction test –measurement of Energy delivered to a 100 Ω load			N
Test Voltage applied to		Measured Energy E1 (J)	Measured Energy E2 (J)	Energy E1 as % of E2 (%)
PATIENT CONNECTION 1 or APPLIED PART with PATIENT CONNECTIONS 2, 3, and 4 of the same APPLIED PART connected to earth				
PATIENT CONNECTION 2 or APPLIED PART with PATIENT CONNECTIONS 1, 3, and 4 of the same APPLIED PART connected to earth				
PATIENT CONNECTION 3 or APPLIED PART with PATIENT CONNECTIONS 1, 2, and 4 of the same APPLIED PART connected to earth				
PATIENT CONNECTION 4 or APPLIED PART with PATIENT CONNECTIONS 1, 2, and 3 of the same APPLIED PART connected to earth				
Supplementary information: For compliance: E1 must at least 90% of E2 E1= Measured energy delivered to 100 Ω with ME Equipment connected; E2= Measured energy delivered to 100 Ω without ME equipment connected.				

8.6.4	TABLE: Impedance and current-carrying capability of protective earth connections				N
Type of ME EQUIPMENT & impedance measured between parts		Test current (A) /Duration (s)	Voltage drop measured between parts (V)	Maximum calculated impedance (mΩ)	Maximum allowable impedance (mΩ)
Me equipment with an appliance inlet impedance between earth pin in the appliance inlet and a protectively earth part		25A/10s			100
The impedance between the protective earth pin in the mains plug of any detachable power supply cord supplied or specified by the manufacturer, when attached to the me equipment, and any part of the me equipment that is protectively earthed		25A/10s			200
Supplementary information: PERMANENTLY INSTALLED ME EQUIPMENT, impedance between PROTECTIVE EARTH TERMINAL and a PROTECTIVELY EARTHED part - Limit 100 mΩ ME EQUIPMENT with an APPLIANCE INLET, impedance between earth pin in the APPLIANCE INLET and a PROTECTIVELY EARTHED part - Limit 100 mΩ ME EQUIPMENT with an APPLIANCE INLET, impedance between earth pin in the protective earth pin on the DETACHABLE POWER SUPPLY CORD and a PROTECTIVELY EARTHED part - Limit 200 mΩ ME EQUIPMENT with a non-DETACHABLE POWER SUPPLY CORD, impedance between the protective earth pin in the MAINS PLUG and a PROTECTIVELY EARTHED part - Limit 200 mΩ					

8.7	TABLE: leakage current				P
Type of leakage current and test condition (including single faults)	Supply voltage (V)	Supply frequency (Hz)	Measured max. value (μ A)	Remarks	
Fig. 13 - Earth Leakage (ER)	—	—	Before /After Humidity	Maximum allowed values: 5 mA NC; 10 mA SFC	
--	--	--	--		
Fig. 14 - Touch Current (TC)	—	—	Before /After Humidity	Maximum allowed values: 100 μ A NC; 500 μ A SFC	
TC, NC	3	d.c.	0/0		
Fig. 15 - Patient Leakage Current (P)	—	—	Before /After Humidity	Maximum allowed values: Type B or BF AP: 10 μ A NC; 50 μ A SFC (d.c. current); 100 μ A NC; 500 μ A SFC (a.c.) Type CF AP: 10 μ A NC; 50 μ A SFC (d.c. or a.c. current)	
P, NC	3	d.c.	d.c.: 0/0	Type BF	
			a.c.: 0/0		
Fig. 16 - Patient leakage current with mains on the F-type applied parts (PM)	—	—	Before /After Humidity	Maximum allowed values: Type B: N/A Type BF AP: 5000 μ A Type CF AP: 50 μ A	
PM, SFC	3	d.c.	1/1	Type BF	
Fig. 17 - Patient leakage current with external voltage on Signal Input/Output part (SIP/SOP)	—	—	Before /After Humidity	Maximum allowed values: Type B or BF AP: 10 μ A NC; 50 μ A SFC (d.c. current); 100 μ A NC; 500 μ A SFC (a.c.) ; Type CF AP: 10 μ A NC; 50 μ A SFC (d.c. or a.c. current)	
--	--	--	--		
Fig. 18 - Patient leakage current with external voltage on metal Accessible Part that is not Protectively Earthed	—	—	Before /After Humidity	Maximum allowed values: Type B or BF AP: 500 μ A Type CF: N/A	
--	--	--	--		
Fig. 19 – Patient Auxiliary Current	—	—	Before /After Humidity	Maximum allowed values: Type B or BF AP: 10 μ A NC; 50 μ A SFC (d.c. current); 100 μ A NC; 500 μ A SFC (a.c.) ; Type CF AP: 10 μ A NC; 50 μ A SFC (d.c. or a.c. current)	
--	--	--	--		
Fig. 15 and 20 – Total Patient Leakage Current with all AP of same type connected together	—	—	Before /After Humidity	Maximum allowed values: Type B or BF AP: 50 μ A NC; 100 μ A SFC (d.c. current); 500 μ A NC; 1000 μ A SFC (a.c.); Type CF AP: 50 μ A NC; 100 μ A SFC (d.c. or a.c. current)	
--	--	--	--		
Fig. 17 and 20 – Total Patient Leakage Current with all AP of same type connected together with external voltage on SIP/SOP	—	—	Before /After Humidity	Maximum allowed values: Type B or BF AP: 50 μ A NC; 100 μ A SFC (d.c. current); 500 μ A NC; 1000 μ A SFC (a.c.); Type CF AP: 50 μ A NC; 100 μ A SFC (d.c. or a.c. current)	
--	--	--	--		

Fig. 16 and 20 – Total Patient Leakage Current with all AP of same type connected together with external voltage on F-type AP	—	—	Before /After Humidity	Maximum allowed values: Type B: NA Type BF: 5000 μ A Type CF: 100 μ A
--	--	--	--	
Fig. 18 and 20 – Total Patient Leakage Current with all AP of same type connected together with external voltage on metal Accessible Part not Protectively Earthed	—	—	Before /After Humidity	Maximum allowed values: Type B & BF: 1000 μ A Type CF: N/A
--	--	--	--	
Function Earth Conductor Leakage Current (FECLC)	—	—	Before /After Humidity	Maximum allowed values: 5 mA NC; 10 mA SFC
--	--	--	--	
Supplementary information:				
Note 1: For EARTH LEAKAGE CURRENT see 8.7.3 d) and 8.7.4.5; Note 2: For TOUCH CURRENT see 8.7.3 c) and 8.7.4.6; Note 3: For PATIENT LEAKAGE CURRENT SEE 8.7.3.b) and 8.7.4.7 Note 4: Total PATIENT LEAKAGE CURRENT values are only relative to equipment with multiple APPLIED PARTS of the same type. See 8.7.4.7 h). The individual APPLIED PARTS complied with the PATIENT LEAKAGE CURRENT values. Note 5: In addition to conditions indicated in the Table, tests conducted at operating temperature and after humidity preconditioning of 5.7, EQUIPMENT energized in stand-by condition and fully operating, max rated supply frequency, at 110 % of the max RATED MAINS VOLTAGE, and after relevant tests of Clause 11.6 (i.e., overflow, spillage, leakage, ingress of water and particulate matter, cleaning & disinfection, & sterilization).				
ER - Earth leakage current TC – Touch current P - Patient leakage current PA – Patient auxiliary current TP – Total Patient current PM - Patient leakage current with mains on the applied parts MD - Measuring device				
A - After humidity conditioning B - Before humidity conditioning 1 - Switch closed or set to normal polarity 0 - Switch open or set to reversed polarity NC - Normal condition SFC - Single fault condition				

8.8.3	TABLE: Dielectric strength test of solid insulating materials with safety function – means of operator protection (MOOP) / means of patient protection (MOPP)				P
Insulation under test (area from insulation diagram)	Insulation Type (1 or 2 MOOP/MOPP)	Reference Voltage		A.C. test voltages in V r.m.s ¹	Dielectric breakdown after 1 minute Yes/No ²
		PEAK WORKING VOLTAGE (U) V _{peak}	PEAK WORKING VOLTAGE (U) V d.c.		
A	2 MOOP	/	3	No test	--
B	2 MOPP	/	3	DC 1414	No
C	1 MOPP	354	--	1500	No
Supplementary information:					
¹ Alternatively, per the Table (i.e., __dc), a d.c. test voltage equal to the peak value of the a.c. test voltage used.					
² A) Immediately after humidity treatment of 5.7, ME EQUIPMENT de-energized, B) after required sterilization PROCEDURE, ME EQUIPMENT de-energized, C) after reaching steady state operating temperature as during heating test of 11.1.1, and D) after relevant tests of 11.6 (i.e., overflow, spillage, leakage, ingress of water, cleaning, disinfection, and sterilization).					

8.8.4.1	TABLE: Resistance to heat - Ball pressure test of thermoplastic parts		P
	Allowed impression diameter (mm)	≤ 2 mm	—
	Force (N)	20	—
Part/material		Test temperature (°C)	Impression diameter (mm)
Enclosure		75	0.85
Insulating material supporting un-insulated Mains Parts		--	--
Supplementary information:			

8.9.2	TABLE: Short circuiting of each single one of the CREEPAGE DISTANCES and AIR CLEARANCES for insulation in the MAINS PART between parts of opposite polarity in lieu of complying with the required measurements in 8.9.4			N
	Specific areas of circuits short-circuited and test conditions	Test in lieu of CREEPAGE DISTANCE or AIR CLEARANCE¹	HAZARDOUS SITUATION observed (i.e., fire hazard, shock hazard, explosion, discharge of parts, etc.)? Yes/No	Remarks
Supplementary information:				
Note 1: AC - AIR CLEARANCE CD - CREEPAGE DISTANCE				

8.9.3.2	Table: Thermal cycling tests on one sample of insulating compound forming solid insulation between conductive parts			N
Part Test	8.9.3.4 - Test duration and temperature for 10 cycles after which the sample was subjected to Humidity Preconditioning per Cl. 5.7	Dielectric test voltage	Dielectric strength test after humidity preconditioning per cl. 5.7 except for 48 h only, Breakdown: Yes/No	Crack or voids in the insulating compound: Yes/No
	68 h at T1 ± 2 °C = ___ °C ¹			
	1 h at 25 °C ± 2 °C			
	2 h at 0 °C ± 2 °C			
	1 or more h at 25 °C ± 2 °C			
Supplementary information:				
¹ T1 = 10 °C above the maximum temperature of relevant part determined per 11.1.1, or 85 °C, the higher of the two. 10 °C not added to T1 when temperature measured by an embedded thermocouple. Used gradual transition from one temperature to another.				

8.9.3.3	Table: Thermal cycling tests on one sample of cemented joint with other insulating parts (see 8.9.3.3)				N
Part tested	Sample	Each test duration and temperature	Dielectric test voltage	Dielectric strength test, Breakdown: Yes/No	
	1	10 Cycles conducted of the following: 1 - 68 h at $T1 \pm 2 \text{ }^\circ\text{C} = \text{---}^\circ\text{C}^1$ 2 - 1 h at $25 \text{ }^\circ\text{C} \pm 2 \text{ }^\circ\text{C}$ 3 - 2 h at $0 \text{ }^\circ\text{C} \pm 2 \text{ }^\circ\text{C}$ 4 - 1 or more h at $25 \text{ }^\circ\text{C} \pm 2 \text{ }^\circ\text{C}$			
	2	Humidity Conditioning per 5.7			
	3	Humidity Conditioning per 5.7			
Supplementary information: ¹ T1 = 10 °C above the maximum temperature of relevant part determined per 11.1.1, or 85 °C, the higher of the two. 10 °C not added to T1 when temperature measured by an embedded thermocouple. Used gradual transition from one temperature to another.					

8.10	TABLE: List of critical components					P
Component/ Part No.	Manufacturer/ Trademark	Type No./model No./	Technical data	Standard No./, Edition	Mark(s) & Certificates of conformity ¹	
Enclosure	Chi Mei Corporation	PA-765(+)	ABS, V-1	UL 94 UL746	UL: E56070	
PCB	Shenzhen SYF Precision Electronics Limited	SYF002	Flame class: V-0, 110°C	UL 94	UL: E469050	
Supplementary information: 1) An asterisk indicates a mark which assures the agreed level of surveillance. See Licenses and Certificates of Conformity for verification.						

8.10 b	TABLE: List of identified components with high integrity characteristics					N
Component/ Part No.	Manufacturer/ Trademark	Type No./model No./	Technical data	Standard No./, Edition	Mark(s) & Certificates of conformity ¹	
Supplementary information: 1) An asterisk indicates a mark which assures the agreed level of surveillance. See Licenses and Certificates of Conformity for verification.						

8.11.3.5	TABLE: Cord anchorages				N
Cord under test	Mass of equipment (kg)	Pull (N)	Torque Nm)	Remarks	
Supplementary information:					

8.11.3.6	TABLE: Cord guard			N
Cord under test	Test mass	Measured curvature	Remarks	
Supplementary information:				

9.2.2.2	TABLE: Measurement of gap “a” according to Table 20 (ISO 13852: 1996)				N
Part of body	Allowable adult gap ¹ , mm	Measured adult gap, mm	Allowable children gap ¹ , mm	Measured children gap, mm	
Body	> 500		> 500		
Head	> 300 or < 120		> 300 or < 60		
Leg	> 180		> 180		
Foot	> 120 or < 35		> 120 or < 25		
Toes	> 50		> 50		
Arm	> 120		> 120		
Hand, wrist, fist	> 100		> 100		
Finger	> 25 or < 8		> 25 or < 4		
Supplementary information: ¹ In general, gaps for adults used, except when the device is specifically designed for use with children, values for children applied.					

9.2.3.2	TABLE: Over-travel End Stop Test		N
ME EQUIPMENT end stop	Test Condition (cycles, load, speed)		Remarks
Supplementary information:			

9.4.2.1	TABLE: Instability—overbalance in transport position		N
ME EQUIPMENT preparation	Test Condition (transport position)		Remarks
Supplementary information:			

9.4.2.2	TABLE: Instability—overbalance excluding transport position		N
ME EQUIPMENT preparation	Test Condition (excluding transport position) Test either 5 ° incline and verify Warning marking or 10 ° incline)	Remarks	
Supplementary information:			

9.4.2.3	TABLE: Instability—overbalance from horizontal and vertical forces		N
ME EQUIPMENT preparation	Test Condition (force used, direction of force, weight of equipment, location of force)	Remarks	
Supplementary information:			

9.4.2.4.2	TABLE: Castors and wheels – Force for propulsion		N
ME EQUIPMENT preparation	Test Condition (force location and height)	Remarks	
Supplementary information:			

9.4.2.4.3	TABLE: Castors and wheels – Movement over a threshold		N
ME EQUIPMENT preparation	Test Condition (speed of movement)	Remarks	
Supplementary information:			

9.4.3.1	TABLE: Instability from unwanted lateral movement (including sliding) in transport position		N
ME EQUIPMENT Preparation	Test Condition (transport position, working load, locking device(s), caster position)	Remarks	
Supplementary information:			

9.4.3.2	TABLE: Instability from unwanted lateral movement (including sliding) excluding transport position		N
ME EQUIPMENT Preparation	Test Condition (working load, locking device(s), caster position, force, force location, force direction)	Remarks	
Supplementary information:			

9.4.4	TABLE: Grips and other handling devices		N
Clause and Name of Test	Test Condition	Remarks	
Supplementary information:			

9.7.5	TABLE: Pressure vessels				N
Hydraulic, Pneumatic or Suitable Media and Test Pressure	Vessel Burst	Permanent Deformation	Leaks	Vessel fluid substance	Remarks
Supplementary Information:					

9.8.3.2	TABLE: PATIENT support/suspension system - Static forces				N
ME EQUIPMENT part or area	Position	Load	Area	Remarks	
Supplementary Information:					

9.8.3.3	TABLE: Support/Suspension System – Dynamic forces due to loading from persons				N
ME EQUIPMENT part or area	Position	Safe Working Load	Area	Remarks	
Supplementary Information:					

10.1.1	TABLE: Measurement of X - radiation		N
Maximum allowable radiation pA/kg (μ Sv/h) (mR/h)		36 (5 μ Sv/h) (0.5 mR/h)	
Surface area under test Surface no./ Description¹		Measured Radiation, pA/kg (μSv/h) (mR/h)	Remarks
1/ /			
2/ /			
3/ /			
4/ /			
5/ /			
6/ /			
7/ /			
8/ /			
9/ /			
10/ /			
Supplementary information: ¹ Measurements made at a distance of 5 cm from any surface to which OPERATOR (other than SERVICE PERSONNEL) can gain access without a TOOL, is deliberately provided with means of access, or is instructed to enter regardless of whether or not a TOOL is needed to gain access			

11.1.1	TABLE: Excessive temperatures in ME EQUIPMENT					P
Model No. :		C101H1				
Test ambient (°C)		40				
Test supply voltage/frequency (V/Hz) ⁴ .. :		See below				
Model No.	Thermo-couple No.	Thermocouple location ³	Max allowable temperature ¹ from Table 22, 23 or 24 or RM file for AP ⁵ (°C)	Max measured temperature ² , (°C)	Remarks	
C101H1	1	Enclosure (external)	48	43.8		
	2	Enclosure (internal)	80	48.6		
	3	PCB	110	46.8		
	4	Battery box	60	43.7		
	5	Screen	48	44.0		
	6	AP	41	38.2	The skin temperature assumed 35°C	
	7	Functional button	48	40.5		
	8	Test corner	90	40.1		
Supplementary information:						
¹ Maximum allowable temperature on surfaces of test corner is 90 °C						
² Max temperature determined in accordance with 11.1.3e)						
³ When thermocouples used to determine temperature of windings, limits of Table 22 reduced by 10 °C.						
⁴ Supply voltage:						
- ME EQUIPMENT with heating elements - 110 % of the maximum RATED voltage;						
- Motor operated ME EQUIPMENT - least favourable voltage between 90 % of the minimum RATED and 110 % of the maximum RATED voltage. ME EQUIPMENT operated under normal load and normal DUTY CYCLE.						
- Combined heating and motor operated and other ME EQUIPMENT - tested both at 110 % of the maximum RATED voltage and at 90 % of the minimum RATED voltage.						
⁵ APPLIED PARTS intended to supply heat to a PATIENT - See RISK MANAGEMENT FILE containing temperatures and clinical effects. Also, see instructions for use.						
Information from Risk Management, as applicable:						

11.1.3d	TABLE: Temperature of windings by change-of-resistance method						N
Temperature T of winding:	t ₁ (°C)	R ₁ (Ω)	t ₂ (°C)	R ₂ (Ω)	T (°C)	Allowed T _{max} (°C)	Insulation class
Supplementary information:							

11.2.2.1	TABLE: Alternative method to 11.2.2.1 a) 5) to determine existence of an ignition source	N
Areas where sparking might cause ignition:		Remarks
1.		
2.		
3.		
4.		
5.		
6.		
Materials of the parts between which sparks could occur (Composition, Grade Designation, Manufacturer):		Remarks
1.		
2.		
3.		
4.		
5.		
6.		
Test parameters selected representing worst case conditions for ME EQUIPMENT:		Remarks
Oxygen concentration (%).....:		
Fuel		
Current (A)		
Voltage (V)		
Capacitance (μF).....:		
Inductance or resistance (h or Ω).....:		
No. of trials (300 Min)		
Sparks resulted in ignition (Yes/No) :		
Supplementary information: Test procedure of 11.2.2.1 a) 5) & Figs 35-37 used for tests. For circuits not in Figs 35-37, test voltage or current set at 3 times the worst case values with other parameters set at worst case values to determine if ignition can occur.		
Information from Risk Management, as applicable:		

11.6.1	TABLE: overflow, spillage, leakage, ingress of water, cleaning, disinfection, sterilization, compatibility with substances			P
Clause / Test Name	Test Condition	Part under test	Remarks	
Clause 11.6.5 ¹ / Ingress of water	IP22	Me equipment	No signs of bridging of insulation or electrical components	
Clause 11.6.6 ² / Cleaning and Disinfection	Test was performed under condition specified in user manual	Me equipment	No signs of deterioration; Dielectric strength and leakage current test passed	
Supplementary information: Note ¹ : Test was conducted under condition specified in IEC 60529. Note ² : Test was performed under condition specified in user manual. For detailed information, please refer to user manual, chapter 1.4 "Definitions and Symbols".				
Information from Risk Management, as applicable: RMF Reference to specific RISKS: Risk management report YMDK-RD-C101H1-0007/A0, whole file.				

13.1.2	TABLE: measurement of power or energy dissipation in parts & components to waive SINGLE FAULT CONDITIONS in 4.7, 8.1 b), 8.7.2, and 13.2.2 relative to emission of flames, molten metal, or ignitable substances				N
Power dissipated less than (W)		15			
Energy dissipated less than (J)		900			
Part or component tested	Measured power dissipated (W)	Calculated energy dissipated (J)	SINGLE FAULT CONDITIONS waived (Yes/No)	Remarks	
Supplementary information:					

13.2	TABLE: SINGLE FAULT CONDITIONS in accordance with 13.2.2 to 13.2.13, inclusive		P
Clause No.	Description of SINGLE FAULT CONDITION	Results observed	HAZARDOUS SITUATION (Yes/No)
13.2.2	Electrical SINGLE FAULT CONDITIONS per Clause 8.1:	—	—
	Continuous emission of red light LED	The max. temperature of SpO2 probe is 38.6°C	No
	Continuous emission of infra-red light LED	The max. temperature of SpO2 probe is 38.7°C	No
	Incorrect connection of battery polarity	The EUT shut down	No
13.2.3	Overheating of transformers per Clause 15.5:	—	—
		No transformer	
13.2.4	Failure of THERMOSTATS according to 13.2.13 & 15.4.2, overloading - THERMOSTATS short circuited or interrupted, the less favourable of the two:	—	—
		No THERMOSTATS	
13.2.5	Failure of temperature limiting devices according to 13.2.13 & 15.4.2, overloading, THERMOSTATS short circuited or interrupted, the less favourable of the two:	—	—
		No temperature limiting device	
13.2.6	Leakage of liquid - RISK MANAGEMENT FILE examined to determine the appropriate test conditions (sealed rechargeable batteries exempted)	—	—
		No liquid used	
13.2.7	Impairment of cooling that could result in a HAZARD using test method of 11.1:	—	—
	Single ventilation fans locked consecutively	No ventilation fan	
	Ventilation openings on top and sides impaired by covering openings on top of ENCLOSURE or positioning of ME EQUIPMENT against walls	No ventilation openings	
	Simulated blocking of filters	No such filter	
	Flow of a cooling agent interrupted	No cooling agent	
13.2.8	Locking of moving parts – Only one part locked at a time – Also see 13.2.10 below:	—	—
		No moving parts	
13.2.9	Interruption and short circuiting of motor capacitors – Motor capacitors short & open circuited¹ – Also see 13.10	—	—
		No motor capacitors	
13.2.10	Additional test criteria for motor operated ME EQUIPMENT in 13.2.8 & 13.2.9:	—	—

Clause No.	Description of SINGLE FAULT CONDITION	Results observed	HAZARDOUS SITUATION (Yes/No)
	For every test in SINGLE FAULT CONDITION of 13.2.8 and 13.2.9, motor-operated EQUIPMENT started from COLD CONDITION at RATED voltage or upper limit of RATED voltage range for specified time:	No motor operated ME EQUIPMENT	
	Temperatures of windings determined at the end of specified test periods or at the instant of operation of fuses, THERMAL CUT-OUTS, motor protective devices		
	Temperatures measured as specified in 11.1.3 d)		
	Temperatures did not exceed limits of Table 26		
13.2.11	Failures of components in ME EQUIPMENT used in conjunction with OXYGEN RICH ENVIRONMENTS:	—	—
		Not intended to be used in conjunction with OXYGEN RICH ENVIRONMENTS	
13.2.12	Failure of parts that might result in a MECHANICAL HAZARD (See 9 & 15.3):	—	—
		No such MECHANICAL HAZARD	
Supplementary information:			
¹ Test with short-circuited capacitor not performed when motor provided with a capacitor complying with IEC 60252-1 and the ME EQUIPMENT not intended for unattended use including automatic or remote control. See Attachment # and appended Table 8.10.			
Information from Risk Management, as applicable:			

15.3	TABLE: Mechanical Strength tests ¹⁾			P
Clause	Name of Test	Test conditions	Observed results/Remarks	
15.3.2	Push Test	Force = 250 N ± 10 N for 5 s	No damage	
15.3.3	Impact Test	Steel ball (50 mm in dia., 500 g ± 25 g) falling from a 1.3 m	--	
15.3.4.1	Drop Test (hand-held)	Free fall height (m) = 1m	No damage	
15.3.4.2	Drop Test (portable)	Drop height (cm) = 5cm	--	
15.3.5	Rough handling test	Travel speed (m/s) =	--	
15.3.6	Mould Stress Relief	7 h in oven at temperature (°C) = 70	No damage	
Supplementary information: ¹⁾ As applicable, Push, Impact, Drop, Mould Stress Relief and Rough Handling Tests (delete not applicable rows).				

15.4.6	TABLE: actuating parts of controls of ME EQUIPMENT – torque & axial pull tests					N
Rotating control under test	Gripping diameter “d” of control knob (mm) ¹	Torque from Table 30 (Nm)	Axial force applied (N)	Unacceptable RISK occurred Yes/No	Remarks	
Supplementary information: ¹ Gripping diameter (d) is the maximum width of a control knob regardless of its shape (e.g. control knob with pointer)						

15.5.1.2	TABLE: transformer short circuit test short-circuit applied at end of windings or at the first point that could be short circuited under single fault condition						N
Primary voltage (most adverse value from 90 % to 110 % of RATED voltage)(V)¹ :						—	
RATED input frequency (Hz)..... :						—	
Winding tested	Class of insulation (A, B, E, F, or H)	Type of protective device (fuse, circuit breaker) /Ratings	Protective device operated Yes/No	Time to THERMAL STABILITY (when protective device did not operate)(Min)	Maximum allowed temp from Table 31 (°C)	Maximum winding temp measured (°C)	Ambient (°C)
Supplementary information:							
¹ Loads on other windings between no load and their NORMAL USE load. Short-circuit applied at end of windings or at the first point that could be short circuited under SINGLE FAULT CONDITION.							

15.5.1.3	TABLE: transformer overload test – conducted only when protective device under short-circuit test operated						N
Primary voltage, most adverse value between 90 % to 110 % of RATED voltage (V)¹ .. :							
RATED input frequency (Hz)..... :							
Test current just below minimum current that would activate protective device & achieve THERMAL STABILITY under method a) (A)..... :							
Test current based on Table 32 when protective device that operated under method a) is external to transformer, and it was shunted (A)..... :							
Winding tested	Class of insulation (A, B, E, F, H)	Type of protective device used (fuse, circuit breaker)/Ratings	Maximum allowed temp from Table 31 (°C)	Maximum winding temp measured (°C)	Ambient (°C)		
Supplementary information:							
¹ Loads on other windings between no load and their NORMAL USE load.							
Time durations: - IEC 60127-1 fuse: 30 min at current from Table 32.							
Non IEC 60127-1 fuse: 30 min at the current based on characteristics supplied by fuse manufacturer, specifically, 30 min clearing-time current. When no 30 min clearing-time current data available, test current from Table 32 used until THERMAL STABILITY achieved.							
- Other types of protective devices: until THERMAL STABILITY achieved at a current just below minimum current operating the protective device in a). This portion concluded at specified time or when a second protective device opened.							

Transformer Model/Type/ Part No	Test voltage applied between	Test voltage, (V)	Test frequency (Hz)	Breakdown Yes/No	Deterioration Yes/No
	Primary & secondary windings				
	Primary winding & frame				
	Secondary winding & frame				

Supplementary information: Tests conducted under the conditions of 11.1, in ME EQUIPMENT or under simulated conditions on the bench. See Clause 15.5.2 for test parameters & other details

Specific area where TOUCH CURRENT measured (i.e., from or between parts of ME SYSTEM within PATIENT ENVIRONMENT)	Allowable TOUCH CURRENT in NORMAL CONDITION (μA)	Measured TOUCH CURRENT in NORMAL CONDITION (μA)	Allowable TOUCH CURRENT in event of interruption of PROTECTIVE EARTH CONDUCTOR, (μA)	Measured TOUCH CURRENT in event of interruption of PROTECTIVE EARTH CONDUCTOR, (μA)
Between Electronic Pulse Stimulator enclosure and computer enclosure				

Supplementary information:

Clause and Name of Test	Test type and condition	Observed results

Supplementary information:

ATTACHMENT FILE 1 photo of the DUT

Photo 1

- complete
- internal
- component
- PCB



Photo 2

- complete
- internal
- component
- PCB



Photo 3

- complete
- internal
- component
- PCB

**Photo 4**

- complete
- internal
- component
- PCB

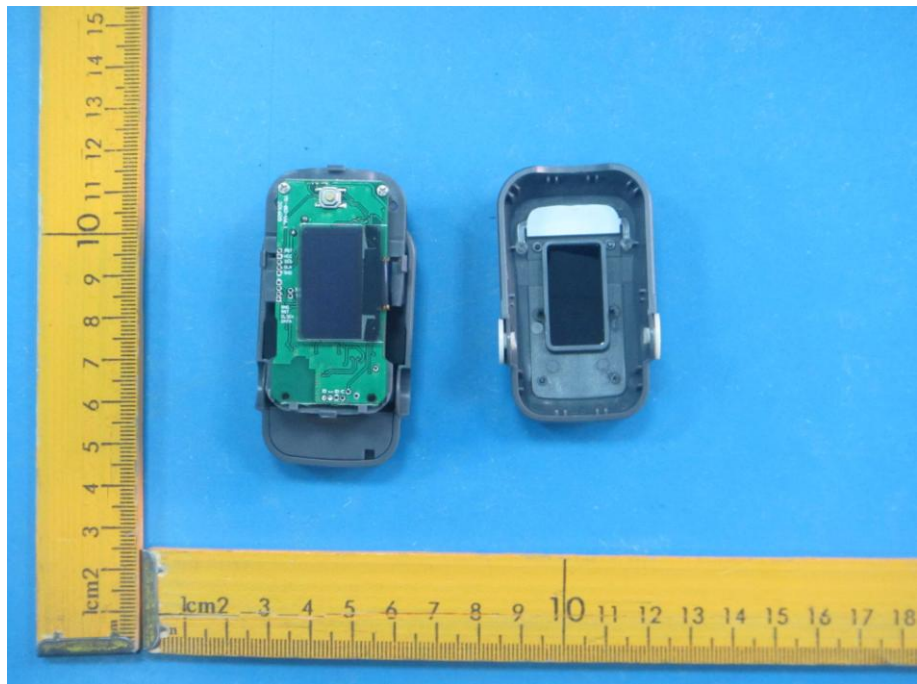

Photo 5

- complete
- internal
- component
- PCB

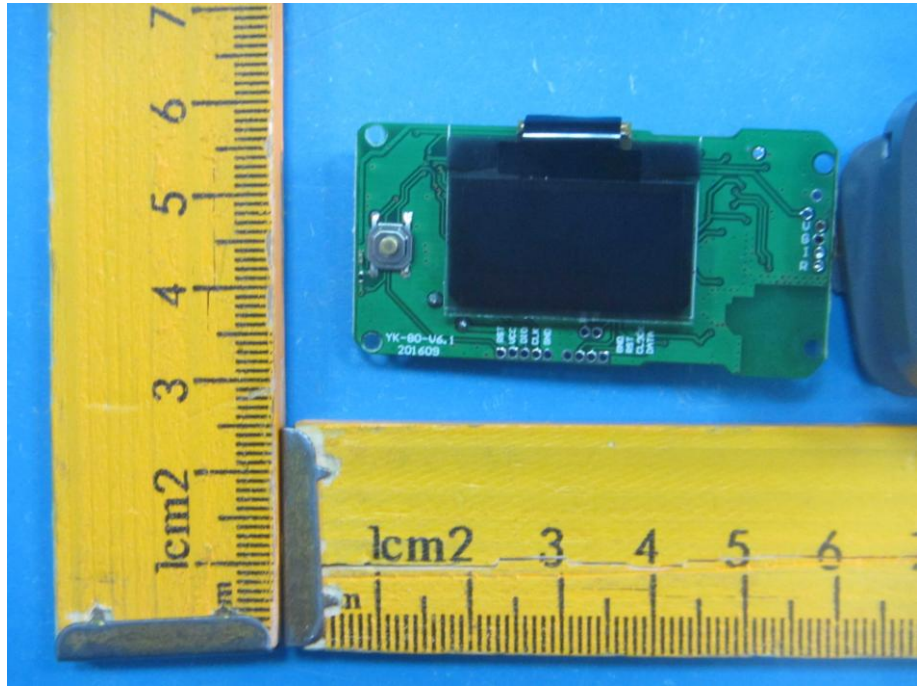

Photo 6

- complete
- internal
- component
- PCB

